

# INSTRUCTION **Book**

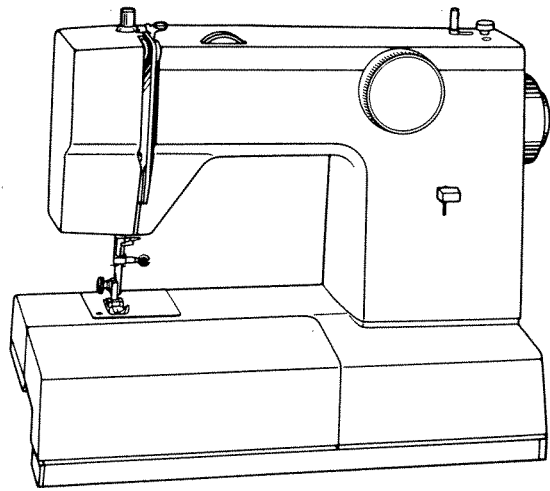

**MODEL**      **1505**  
                    **1510**

SEWING MACHINE

Record in space provided below the Serial No. and Model No. of this appliance.

The Serial No. is located Rear of arm.

The Model No. is located Rear of arm.

Serial No. \_\_\_\_\_

Model No. 1505, 1510

Retain these numbers for future reference.

# CONTENTS



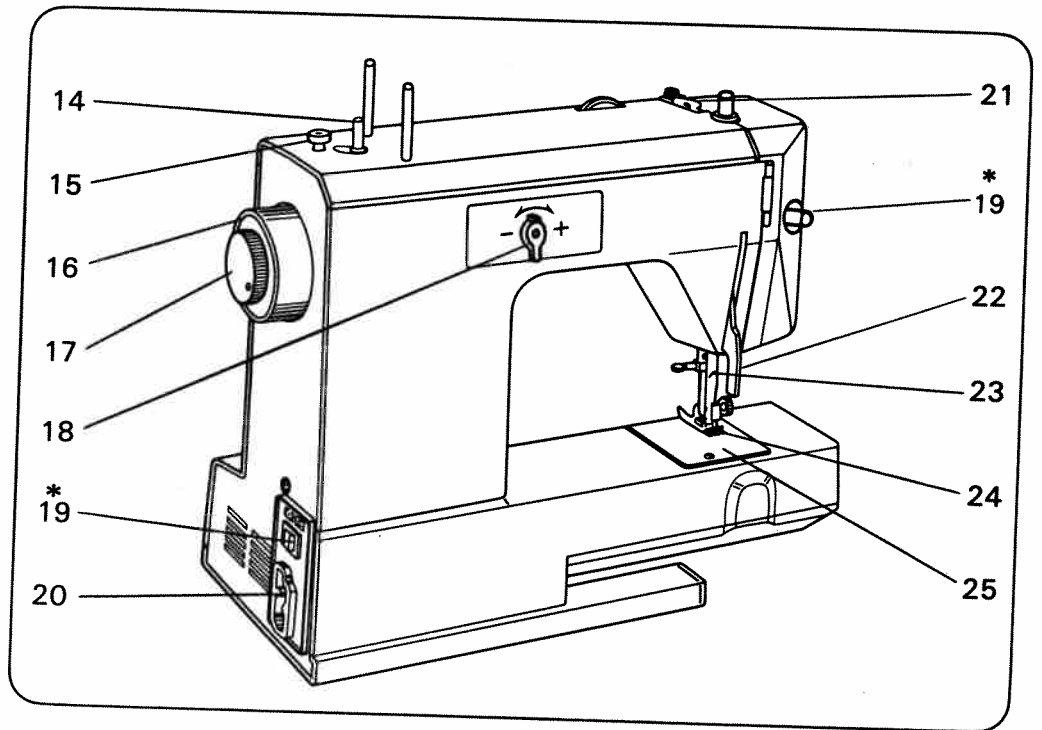
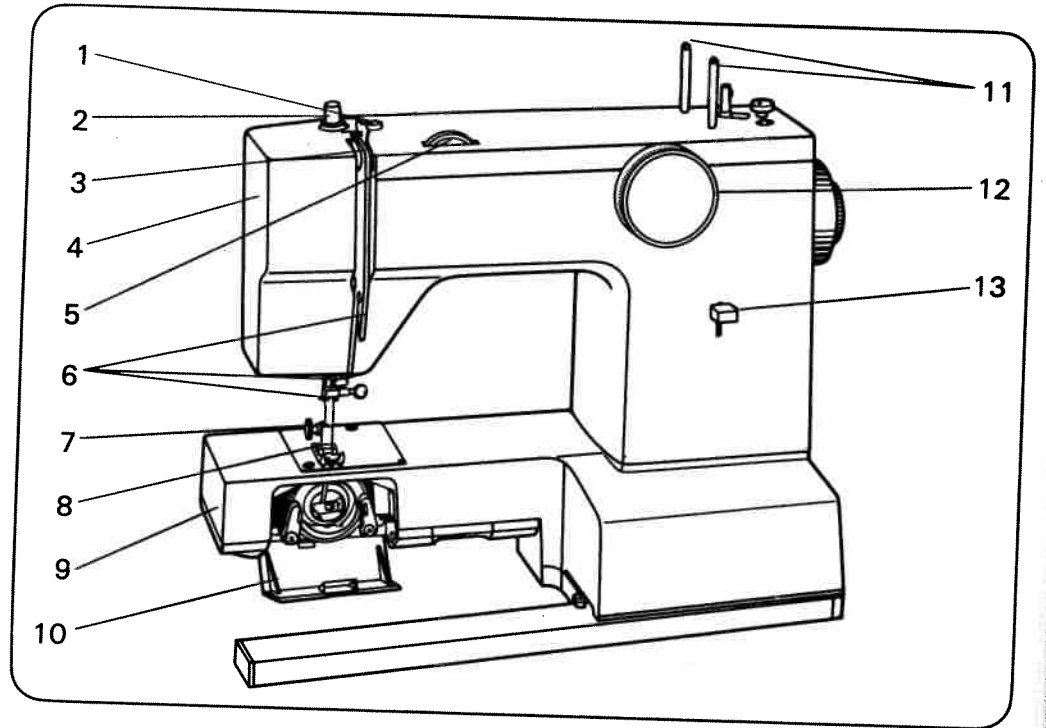







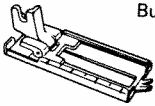

1. NAMES OF PARTS.....	1
2. ACCESSORIES.....	3
3. BEFORE SEWING.....	4
Detachable Extension Table.....	4
Connecting Foot Controller and Power Cord.....	5
Setting Spool Pins.....	6
Changing Foot.....	7
Changing Needle.....	8
Bobbin Winding.....	9
Inserting Bobbin.....	12
Adjusting Lower Tension.....	13
Darning Plate.....	13
Threading Upper Tension.....	14
Drawing Up Lower Tension.....	15
Foot Pressure.....	15
Fabric, Thread and Needle Table.....	16
4. STARTING TO SEW.....	17
Turning a Square Corner.....	17
Pattern Selection Dial.....	18
Starting to Sew.....	19
Double Presser Foot Lifter.....	19
Reverse Sewing.....	19
Cloth Guide.....	20
Adjusting Thread Tension.....	20
5. STRAIGHT SEWING.....	21
6. ZIGZAG SEWING.....	21
Thread Tension for Zigzag Stitch.....	21
7. MAKING BUTTONHOLES.....	22
Determine Length.....	22
Left and Right Side Balance of Buttonhole.....	24
Cutting Buttonholes.....	25
Corded Buttonholes.....	25
8. OVERCASTING.....	26
9. BLIND HEM STITCH.....	27
Elastic Blind Hem Stitch.....	28
10. SHELL STITCHING.....	29
11. MENDING.....	30
Mending a Rip.....	30
12. STRETCH STITCHING.....	31
Adjusting Stretch Stitch Balance.....	31
13. STRETCH SEAMS.....	32
Straight Stretch Stitching.....	32
Rick-Rack Stretch Stitching.....	32
14. LAPPED SEAM SEWING.....	33
15. BRIAR STRETCH.....	34
16. OVERLOCKING.....	34
17. SEWING ON BUTTONS.....	35
18. ZIPPER SEWING.....	36
19. ROLL HEMMING.....	37
20. QUILTING.....	38
21. EMBROIDERY.....	39
22. MAINTENANCE.....	40
Cleaning.....	40
Oiling.....	41
23. TROUBLE CHART.....	42
Changing Light Bulb.....	43

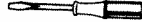
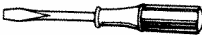

## **1. NAMES OF PARTS**

- 1 Thread guide for bobbin winding
  - 2 Pressure Regulator
  - 3 Take-up lever
  - 4 Face cover
  - 5 Upper thread tension dial
  - 6 Thread guide for upper threading
  - 7 Presser foot thumb screw
  - 8 Presser foot
  - 9 Free arm
  - 10 Shuttle cover
  - 11 Spool pins
  - 12 Pattern selection dial
  - 13 Reverse sewing lever
  
  - 14 Bobbin winding spindle
  - 15 Bobbin winding stopper
  - 16 Handwheel
  - 17 Stop motion knob
  - 18 Adjuster for buttonhole stitch balance and stretch stitch balance
  - 19 Switch \*
  - 20 Socket
  - 21 Thread guide for upper threading
  - 22 Presser foot lifter
  - 23 Thread cutter
  - 24 Feed dog
  - 25 Needle plate
- \*Specifications vary from country to country.

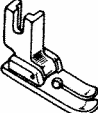
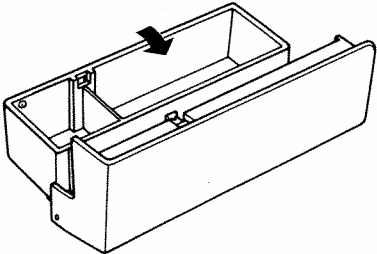
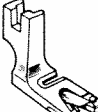
## 2. ACCESSORIES

 <p>Buttonhole foot</p>	 <p>Ordinary needles # 14 (3 pcs.)</p>  <p>Ball point needle (1 pc.)</p>
 <p>Button sewing foot</p>	
 <p>Zipper foot</p>	<p>Spoolpin</p> 
 <p>Buttonhole cutter</p>	<p>Screw drivers (small) (large)</p>  
 <p>Darning plate</p>	<p>Oiler</p> 
 <p>Bobbins (3 pcs.)</p>	<p>Felts. (2 pcs.)</p> 
<p>*</p>  <p>Straight stitch foot</p>	 <p>Accessories are stored in built-in compartment at front of extension table.</p>
<p>*</p>  <p>Roll hemming foot</p>	
<p>*</p>  <p>Quilting guide</p>	
<p>*</p>  <p>Cloth guide</p>	

\* Option accessory.

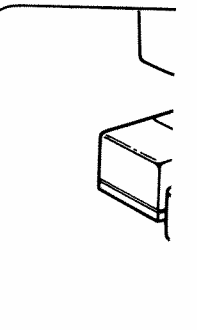
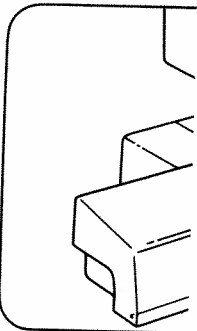
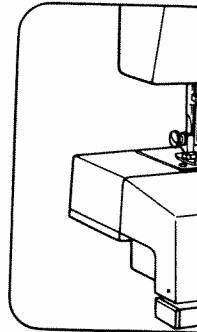

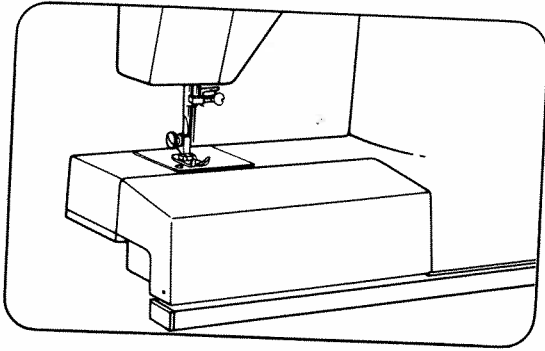

### 3. BEFORE SEWING

Machine is stored in flat-bed style which makes your work easier in ordinary sewing.

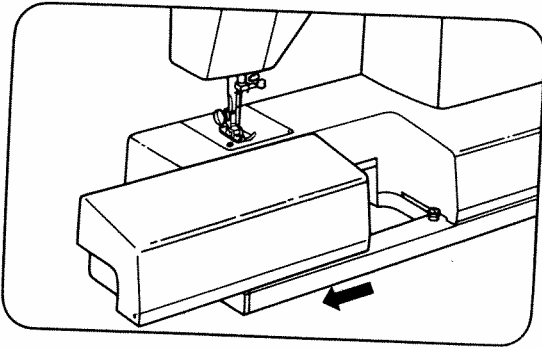

#### Detachable Extension Table

Slide table off and the machine is used as a free-arm model.

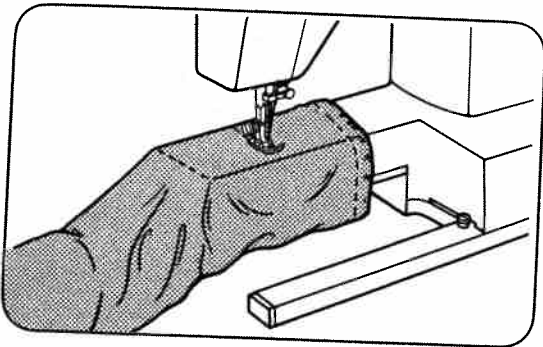

Free-arm is convenient to sew or embroider; trousers, sleeves, cuffs of T-shirts, blouses, etc.

Do vice-versa of above steps to attach extension table.

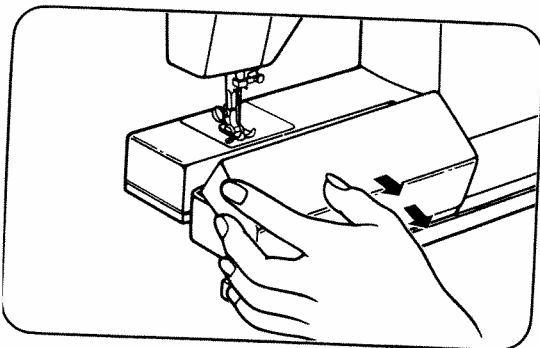

To open lid of accessory box, push it open, as illustrated.

### Connecting Foot Controller and Power Cord

Connect foot controller and power cord ① ②.

Before plugging in your machine, be sure that voltage is same as that of your machine. (written on a plate at back of machine)

\*Specifications vary from country to country.

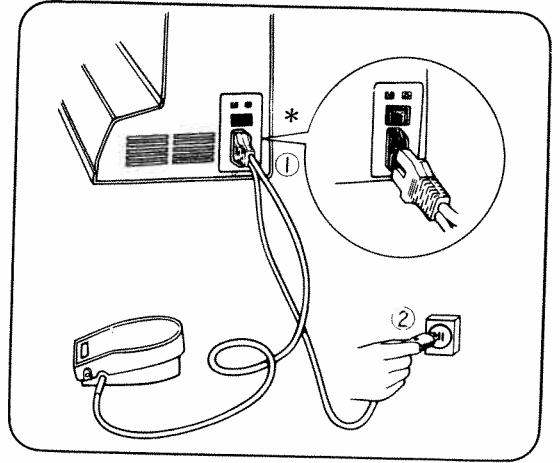

Switch on, put power on the machine and turn on the sewing light.

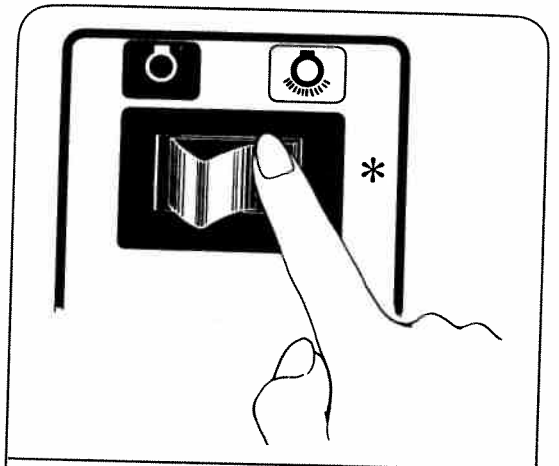

Push button to turn sewing light on and off.

Always switch off or unplug machine when not in use.

\*Specifications vary from country to country.

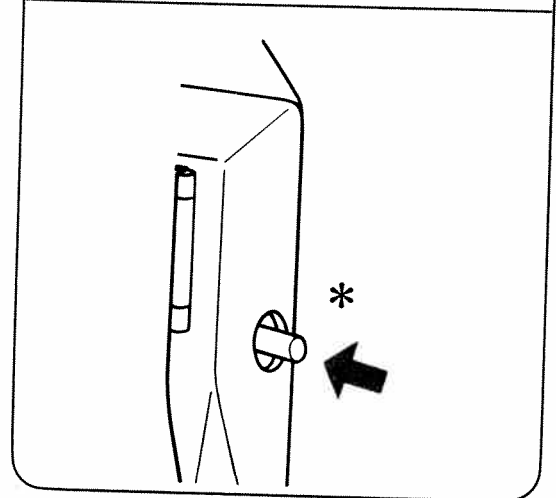

The more you press foot controller,  
the faster the machine runs.

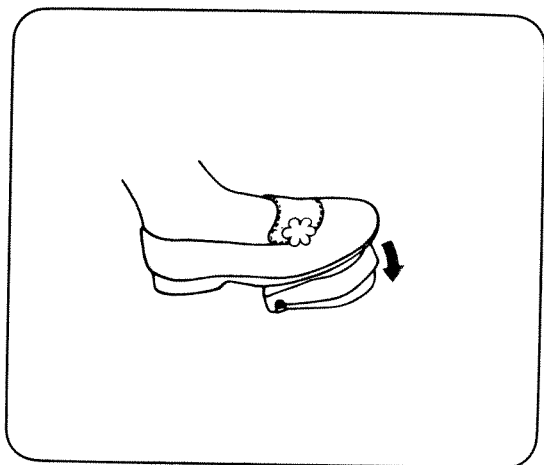

### Setting Spool Pins

Spool Pins are packed in accessory  
box.

Screw thread spool pins in place  
securely with a screw driver.

Place the felts as shown.

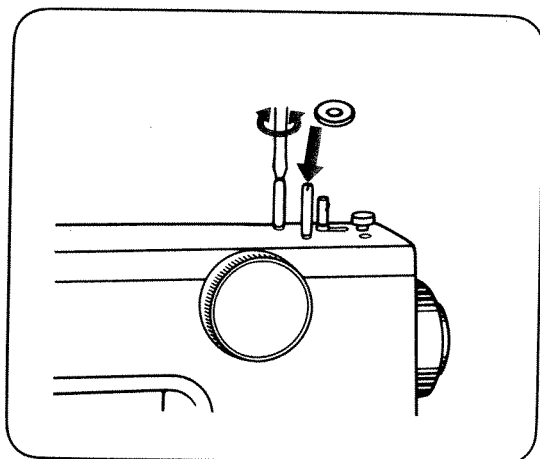

## Changing Foot

Raise presser foot lifter ①.

Set needle in the highest position by turning handwheel towards you ②.

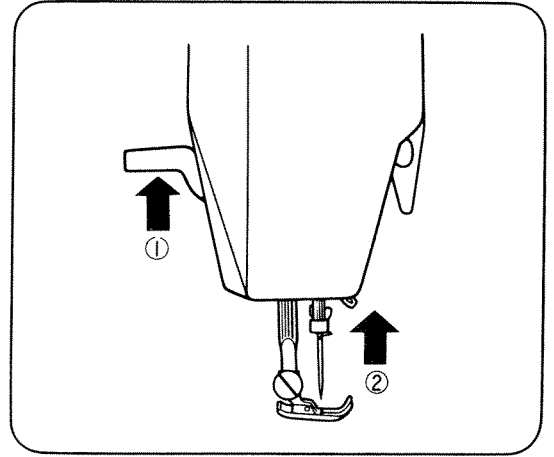

Remove foot holder by loosening screw with screwdriver.

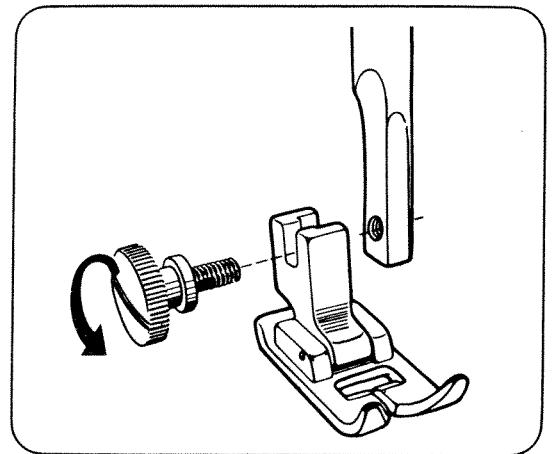

Replace screw-snap type presser foot and tighten screw.

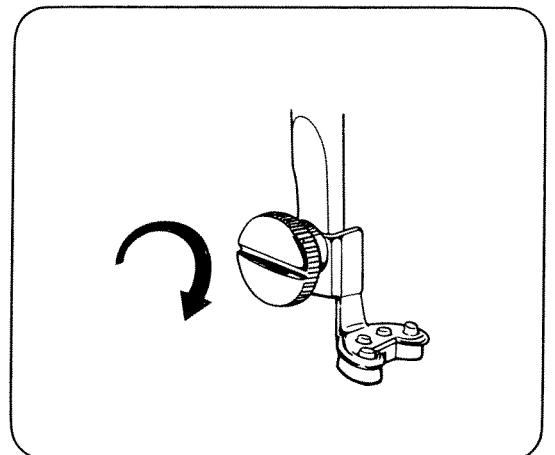

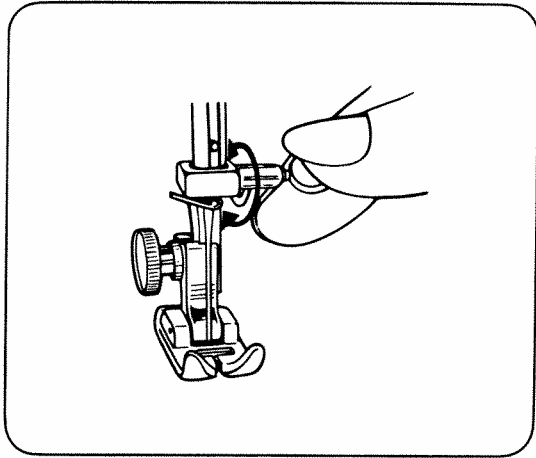

### Changing Needle

Set needle in the highest position by turning handwheel towards you.

Loosen needle clamp screw and take out needle.

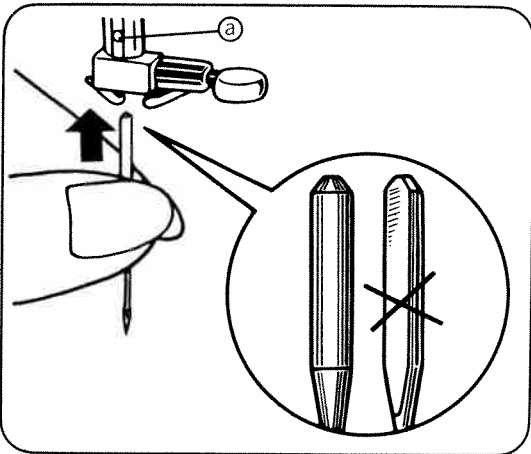

With flat side away from you, insert a new needle into groove of needle bar.

Push needle into clamp until it reaches stopper (a) and tighten needle clamp screw firmly.

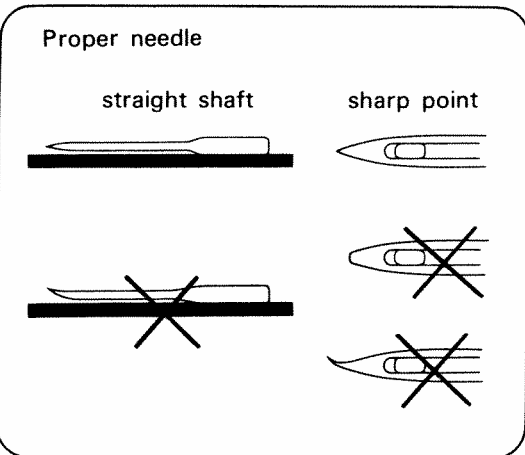

Always use a straight needle with a sharp point.

Using defective or worn needles not only causes stitch skipping, breakage of needles or snapping of thread; it also can damage hook and needle plate.

## Bobbin Winding

Set needle in the highest position by turning handwheel towards you.

Open shuttle cover.

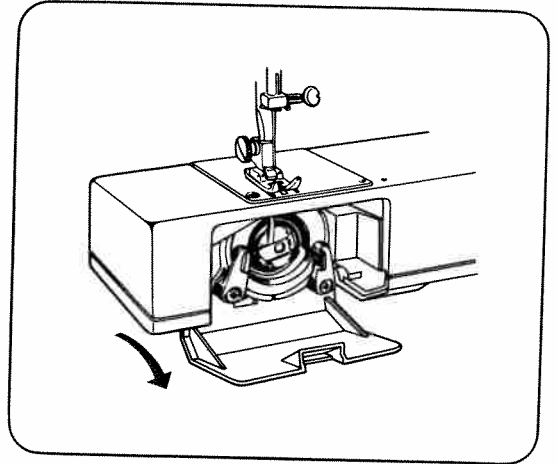

Open latch of bobbin case and take it out.

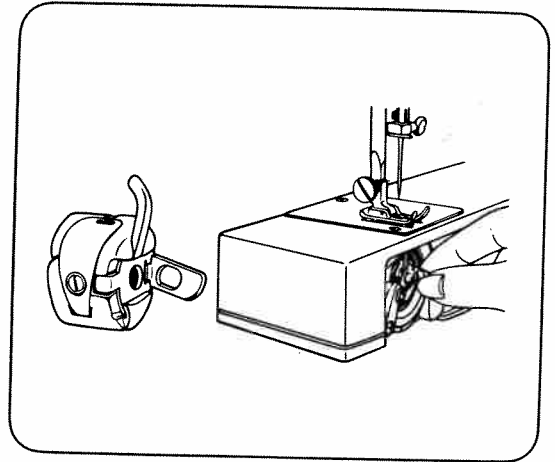

Close latch of bobbin case and bobbin comes out easily.

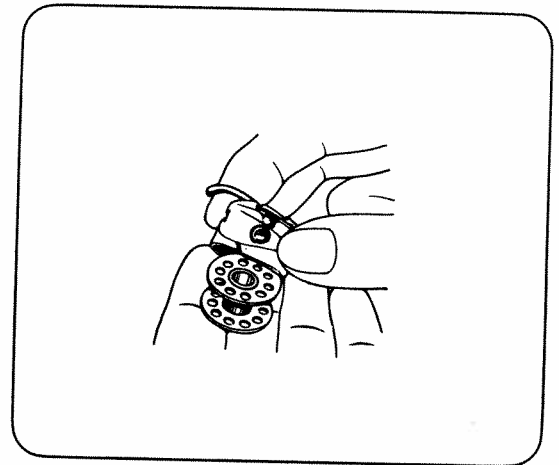

Mount spool pin on top cover.

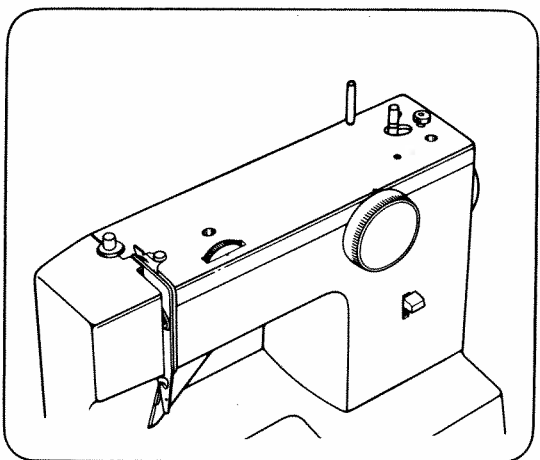

Put a spool on spool pin.  
Draw thread from spool pin through thread guide and pre-tension device, following numbers ① and ②.

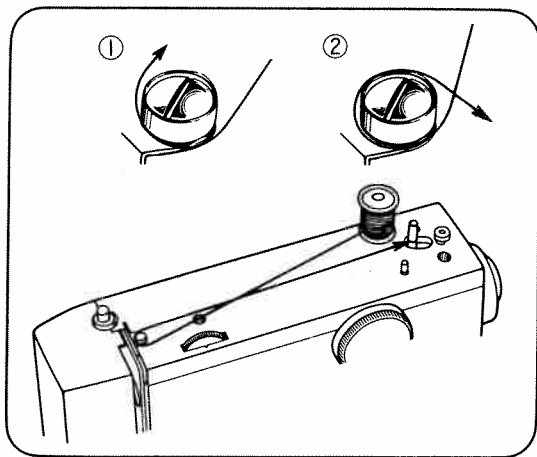

Wind thread clockwise around bobbin several times.  
Push bobbin on to spindle.

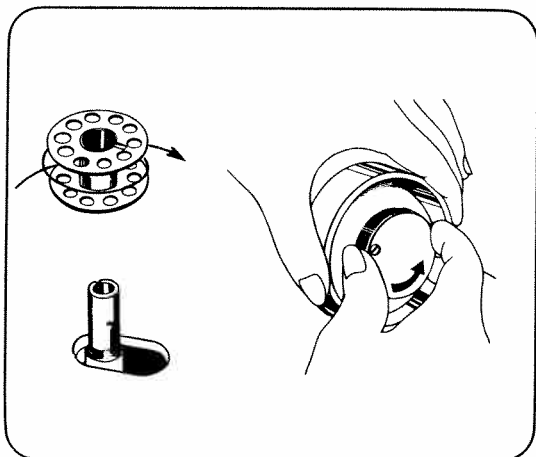

Holding handwheel with your left hand disengage handwheel by unscrewing stop motion knob.

Push bobbin to right and press down foot controller.

Machine stops automatically when bobbin is full.

Push bobbin to left, to disengage from wheel.

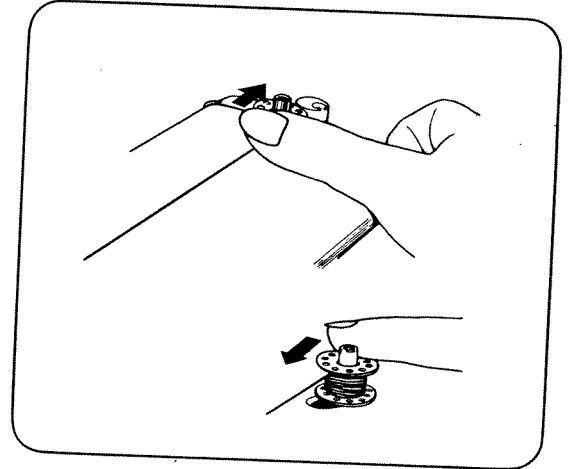

Take off bobbin from spindle and cut thread.

Retighten stop motion knob.

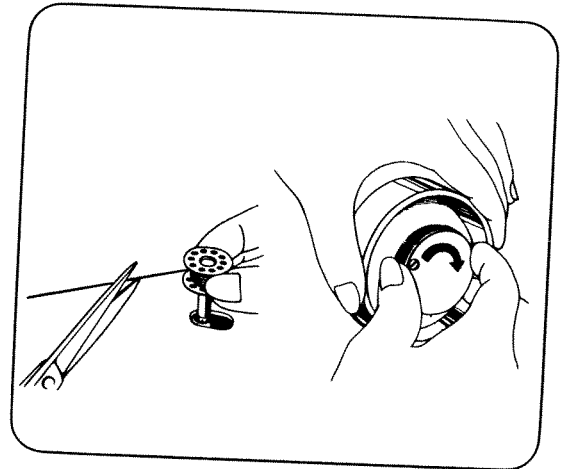

If bobbin is wound unevenly as shown, open face cover and loosen set-screw of the guide for bobbin winding: Use screw driver to adjust height.

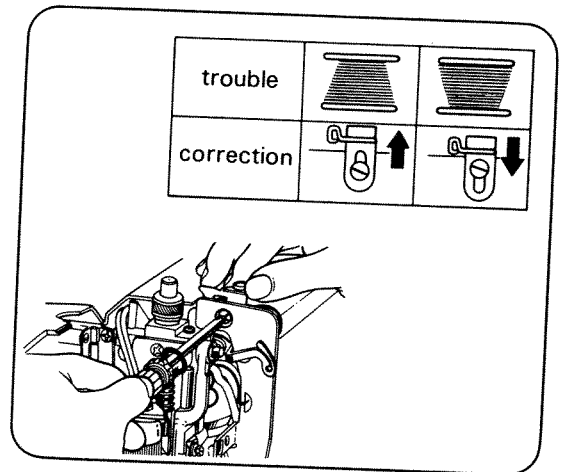

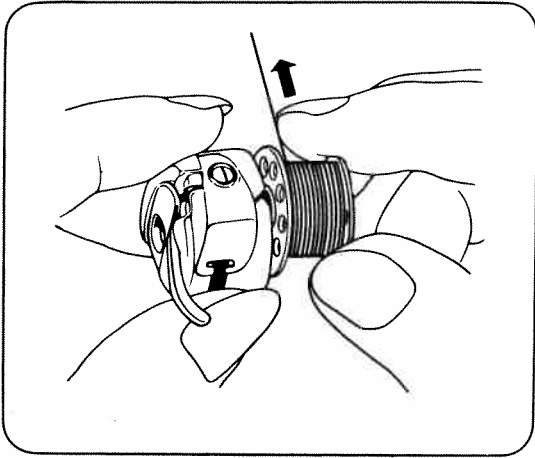

### Inserting Bobbin

Place bobbin in its case with thread running in direction of arrow. (clockwise)

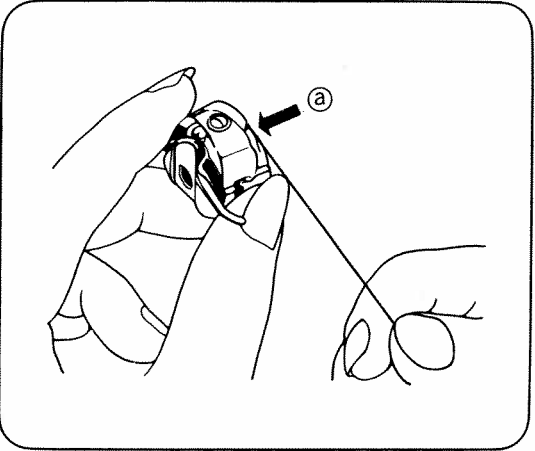

Guide thread into slot (a) of bobbin case.

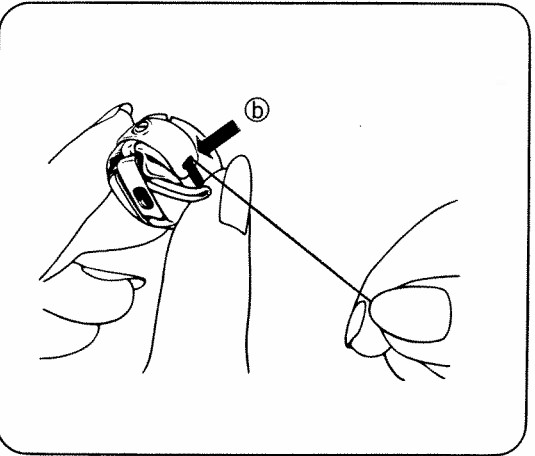

Pulling thread to left, bring it under tension spring then to delivery eye (b).

### Adjusting Lower Tension

To test bobbin tension, hang and shake bobbin case as shown.

At proper tension bobbin case will gradually drop a small amount.

To adjust tension, turn adjusting screw with small screwdriver.

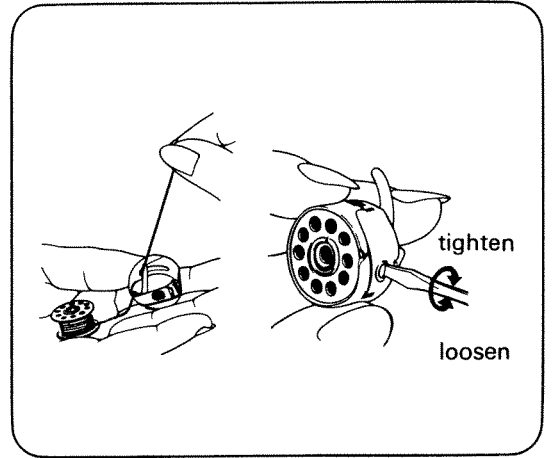

Raise needle in the highest position.

Leave end of thread of about 10 cm (4") from bobbin case.

Take hold of latch and push bobbin case into hook.

Release latch when bobbin case is fully inserted.

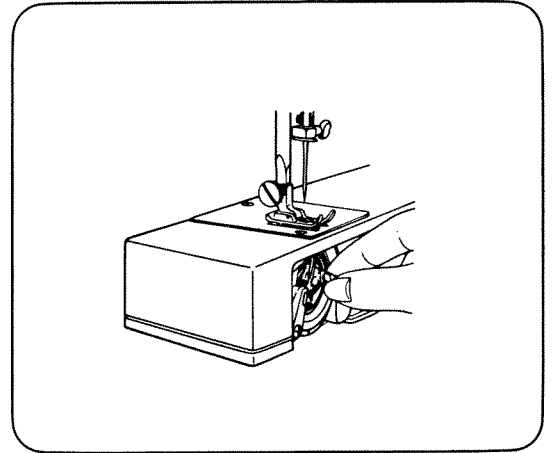

### Darning Plate

There are a few times when you want to control the feeding of the fabric yourself. Raise needle to its highest position and raise presser foot. Place darning plate over needle plate aligning two pins of darning plate with holes of needle plate.

You may then determine the movement of the fabric yourself. See page 39 for embroidery.

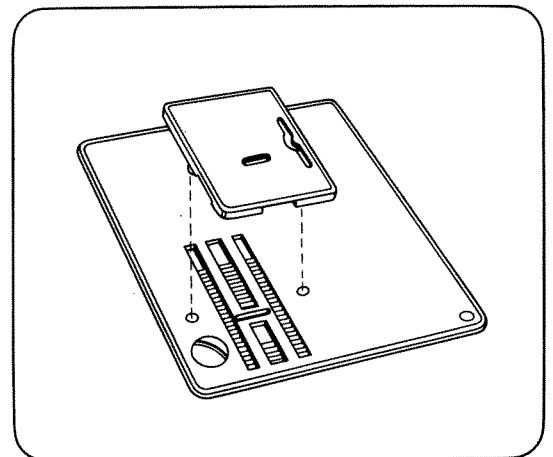

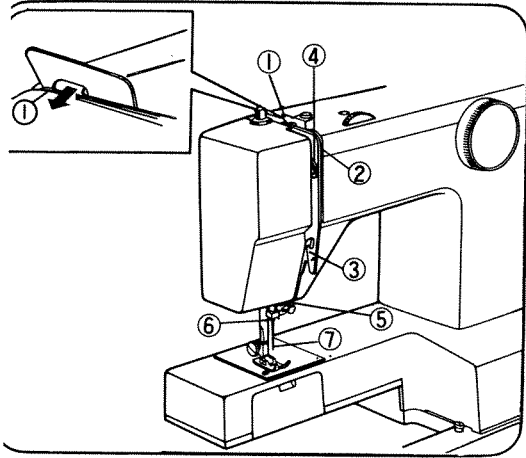

## Threading Upper Thread

Raise presser foot lifter.  
 Raise take-up lever to the highest position by turning handwheel towards you.

Thread following numbers ①-⑦.

Pass thread through guide ①.

Lead thread either side of tension disc ②.

Hook the thread under the guide ③ as shown.

Thread take-up lever ④.

Pass thread to guide ⑤ from right to left, and guide ⑥ (left one) then needle eye ⑦.

Leave end of thread of about 15 cm (6").

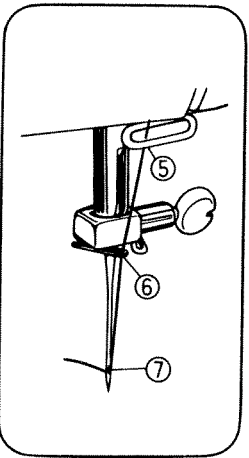
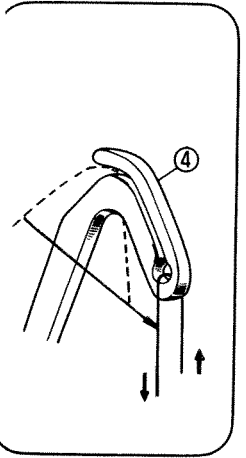
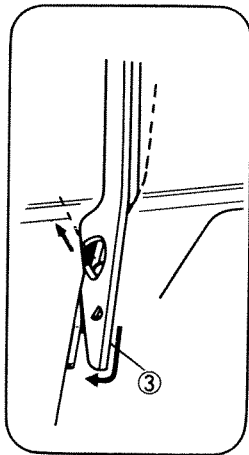
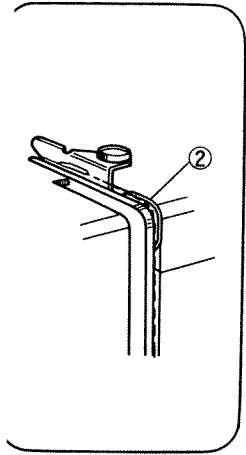

### Drawing Up Lower Thread

Hold end of upper thread with left hand.

Turn handwheel slowly towards you until needle moves down and up again.

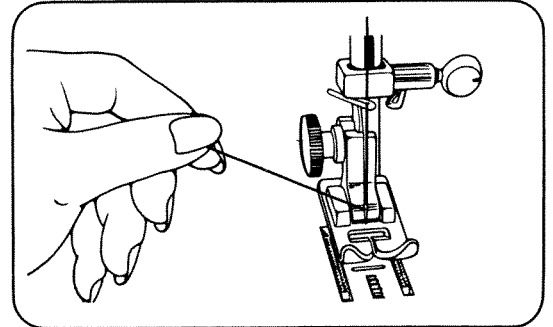

Pull upper thread slowly and lower thread will be brought up in a loop.

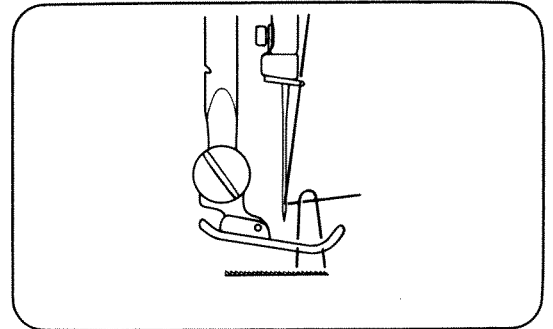

Pull out both threads to about 15 cm (6") and place them together under presser foot on left.

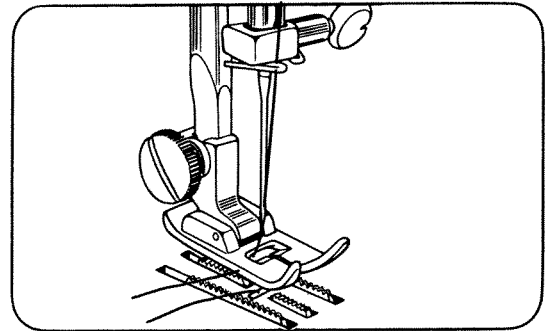

### Foot Pressure

Push down the outer ring of the pressure regulator. This will release the pressure on the presser foot. To increase the pressure, push down inner pin until suitable pressure is obtained.

Insufficient pressure may cause poor feeding of the fabric, skipped stitches, or difficulty in guiding the fabric. If feed dogs or presser foot marks appear on the fabric, reduce the pressure.

When sewing multiple thickness or heavy fabric, reduce the pressure. Increase pressure when sewing lighter weight fabrics.

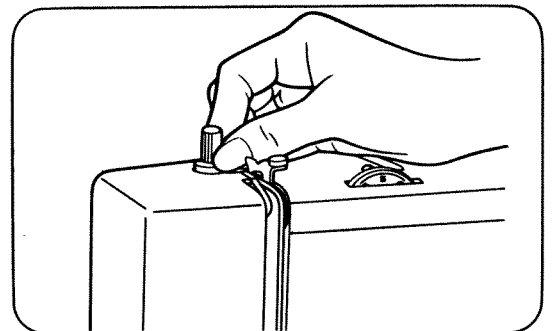

## Fabric, Thread and Needle Table

FABRIC	THREAD			NEEDLE			REMARKS
	European Cotton	Mercerized Cotton	Cotton Covered Polyester, Silk, Nylon	European 705	U.S. Size 15x1	Point Style	
VERY SHEER; Lace, Voile, Chiffon, Net	70	60	Silk Nylon	65-70	9	Regular	Loosen upper tension one or two points
SHEER; Blouse Crepe, Lawn, Organdy, Taffeta	50-70	60	Silk Nylon	65-70	9	"	
LIGHT-WEIGHT; Crepe, Wool, Brocade, Velvet	30	50	Silk	75-80	11	"	
MEDIUM; Wool, Silk, Linen, Velvetten, Cotton Faille, Terrycloth	30	50	Silk	80-90	11-14	"	
HEAVY; Denim, Duck, Sailcloth	30	Heavy Duty	C.C.Poly.	100	16	"	
EXTRA HEAVY; Upholstery, Canvas, Awning	30	Heavy Duty	C.C.Poly.	120	19	"	
[KNITS]							
LIGHT-WEIGHT; Tricot Power net	50-70	60	Silk Nylon	70	9	Light Ball	
MEDIUM-WEIGHT; Jersey, Double Knit, Power Net	30	50	Silk Nylon C.C.Poly.	70-80	9-10	Light to Medium Ball	
HEAVY-WEIGHT; Double knit, Power Net	30	50	Silk Nylon C.C.Poly.	80-90	11-14	Medium to Heavy Ball	
FAKE-FURS, VELOURS	30	Heavy Duty	C.C.Poly.	90-100	14-16	Ball or Sharp	
[LEATHER]							
VINYLS FILMS	30	50	C.C.Poly.	90	14	Wedge	
LIGHT-TO-MEDIUM-WEIGHT	30	50	C.C.Poly.	90-100	14-16	Wedge	
HEAVY LEATHER	30	Heavy Duty	C.C.Poly.	100-110	16-18	Wedge	
[DECORATIVE TOUCHES]							
TOP STITCHING	Silk twist			100-110	16-18	Regular	
MACHINE EMBROIDERY	Size 50-70			65-80	9-11	Regular	

## 4. STARTING TO SEW

Now that you are familiar with the controls on your machine and with the accessories provided for the machine, you are ready to start to sew with your new sewing machine. Below are some good habits to follow each time you sit down to sew:

1. Test the needle: it should be straight, properly set and sharp on the point. It should be the correct size for the fabric and thread being used. Do not be afraid to change your needle frequently. Many of the new fabrics made of synthetic blends tend to dull the needles more easily than fabrics made of natural fibers.
2. Before placing the material on the machine, see that the ends of the threads have been drawn about 6 inches to the rear of the machine. Hold on to threads during the sewing of the first 3 or 4 stitches of the seam.
3. Test the machine stitch on a scrap of fabric you plan to use. The fabric should be double thickness. Adjust the machine for the length of stitch and tension suitable to your fabric.
4. Fabric should be placed under the presser foot with the bulk of the material to the left of the needle and the right edge of the material placed on the appropriate seam marking for desired seam edge.
5. Run the machine at a slow even speed. The more pressure you put on the foot control, the faster the machine will sew.
6. Fasten each seam by back tacking at the beginning and end of the seam.
7. Always finish sewing each seam with the needle at its highest point.
8. Guide the fabric gently with your hand in front of the needle. Never pull or hold the fabric in such a way that the normal feeding is altered.
9. When turning the hand wheel manually, always turn it toward you.

### Turning A Square Corner

To turn a square corner  $5/8''$  from the fabric edge, stop stitching with the needle tip piercing the fabric, when reaching the cornering guide as shown. Raise the presser foot, turn fabric. New stitching line will align with  $5/8''$  seam guide on side of needle plate. Lower the presser foot and begin stitching in new direction.

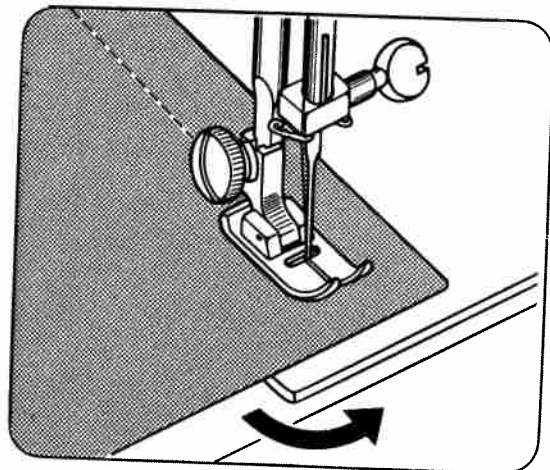

## Pattern Selection Dial

The desired stitch will be obtained by turning the stitch selector, it can be turned either to the right or to the left.

Note: When operating selector, make sure needle is in the highest position.

### The Stitches Are Shown as Below.

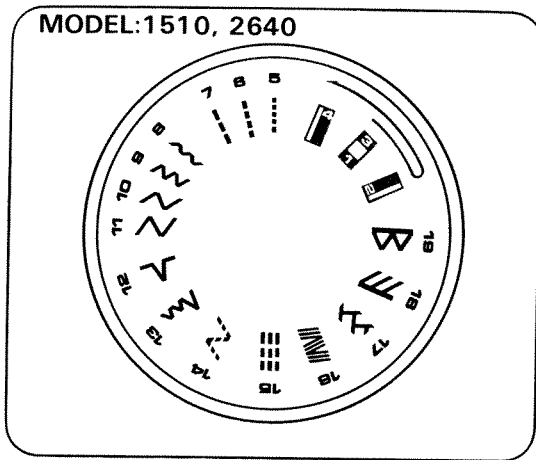

- 1 Bartack stitch of buttonhole.
- 2 Left side stitch of buttonhole.
- 3 Right side stitch of buttonhole.
- 4 Straight stitch (3 kinds of stitch length)
- 5,6,7 Zigzag stitch (4 kinds of zigzag width)
- 8,9 Blind stitch.
- 10 Stretch blind stitch.
- 11 Mending stitch.
- 12 Straight stretch stitch
- 13 Rickrack stitch.
- 14 Briar stretch stitch
- 15 Feather stretch stitch
- 16 Overcast stretch stitch.

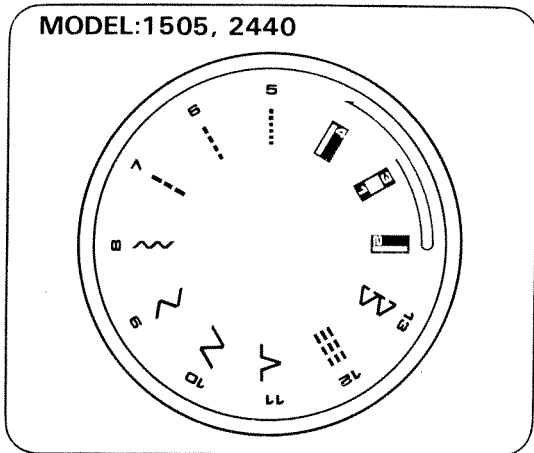

- 1 Bartack stitch of buttonhole.
- 2 Left side stitch of buttonhole.
- 3 Right side stitch of buttonhole.
- 4 Straight side stitch (3 kinds of stitch length)
- 5,6,7 Zigzag stitch (3 kinds of zigzag width)
- 8,9 Blind stitch.
- 10 Straight stretch stitch.
- 11 Overcast stretch stitch.

### Starting to Sew

Place fabric under foot about 1 cm (0.4") inside the edge.  
Lower presser foot lifter.

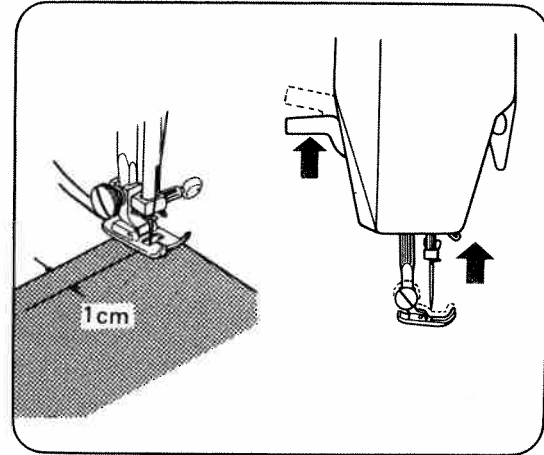

### Double Presser Foot Lifter

In order to obtain a larger opening when using very thick materials, firmly push presser foot lifter up as far as it will go.

### Reverse Sewing

To reinforce seam, sew backwards to the edge of fabric by pushing down reverse sewing lever.

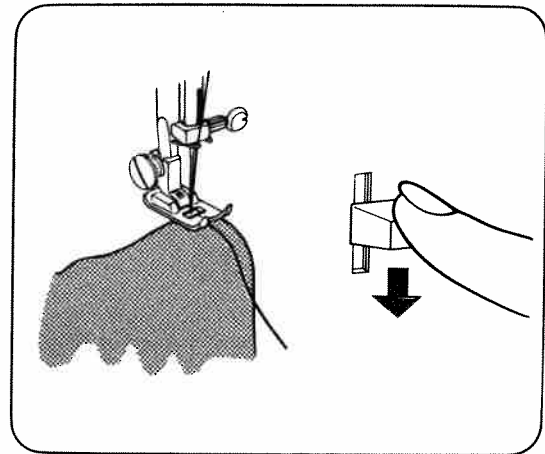

Release lever and commence forward sewing guiding fabric by hand as it is fed.  
Never pull material.

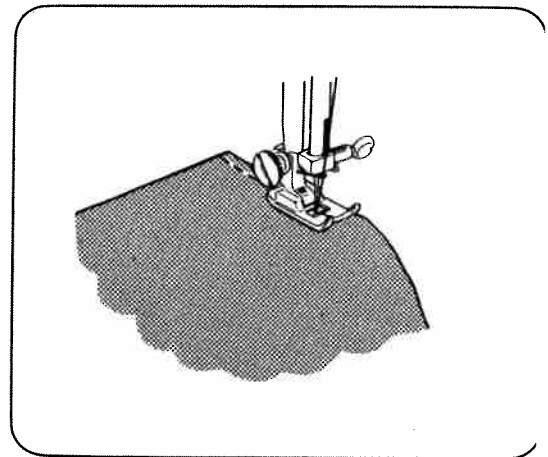

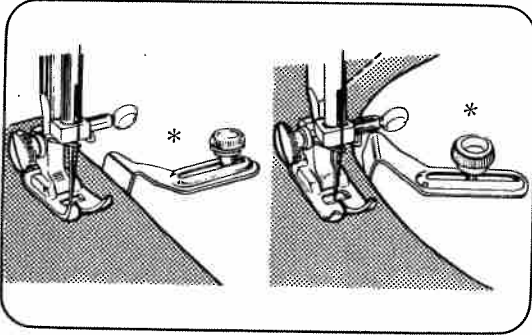

### Cloth Guide

\* Option accessory.

Use cloth guide when sewing a long seam of regular distance from edge of material.

Set guide in hole on arm, at right of needle plate, and adjust distance.

Run machine with edge of fabric touching guide.

Position cloth guide at an angle to sew a curved seam.

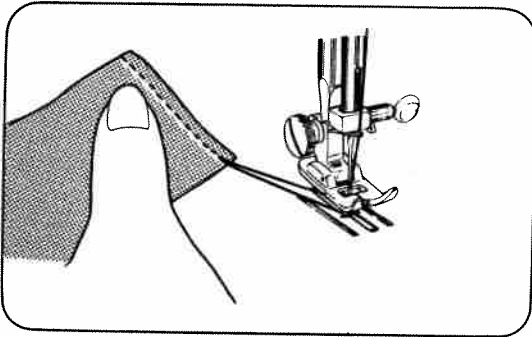

Sew reverse stitches for reinforcement at end of seam.

Draw fabric to left when sewing is finished.

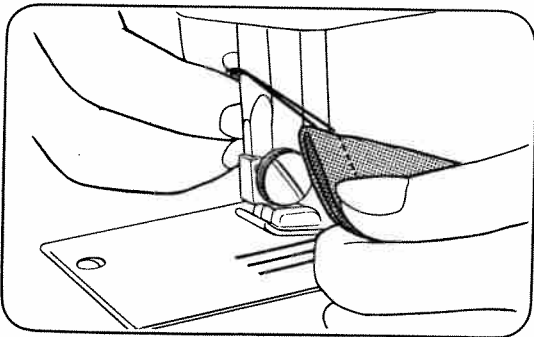

Cut threads with thread cutter behind presser bar.

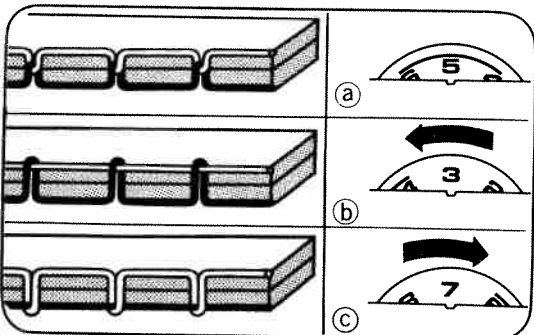

### Adjusting Thread Tension

Test stitch performance on a scrap of material you are going to use.

With correct tension (a), upper and lower threads tension is equal and strong enough to lock both threads in center.

If upper tension is too tight (loose), upper (lower) thread lies straight along upper (lower) surface of fabric (b.c). Correct by turning tension dial.

## 5. STRAIGHT SEWING

Set machine as shown.

\* **Option accessory.**

3 kinds of straight stitch lengths can be selected as shown below.

Stitch Selector	Stitch length
No. 5	2 <sup>mm</sup> / <sub>m</sub>
No. 6	3 <sup>mm</sup> / <sub>m</sub>
No. 7	4 <sup>mm</sup> / <sub>m</sub>

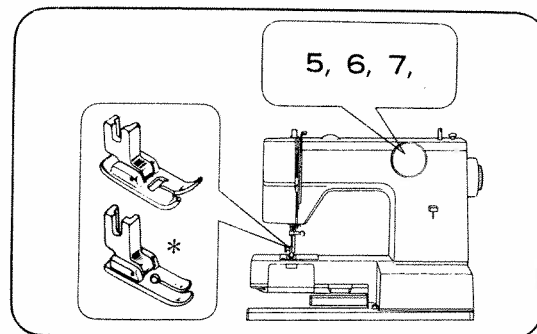

## 6. ZIGZAG SEWING

Set machine as shown.

To prevent seam ends unravelling, set machine for straight stitch and sew in reverse at beginning and ending of seam.

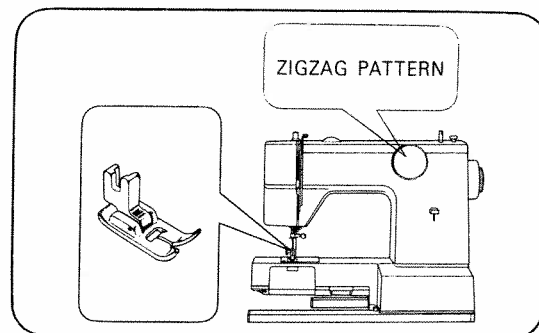

4 kinds or 3 kinds of zigzag patterns can be selected.

\* **No.11 for model 1510 and 2640 only.**

Stitch Selector	Zigzag Width	Stitch Length
No. 8	2mm	1mm
No. 9	3mm	2mm
No. 10	4mm	3mm
* No. 11	5mm	4mm

## Thread Tension for Zigzag Stitch

Better-looking zigzag stitching requires less upper tension than straight stitching.

Loosen upper tension slightly.

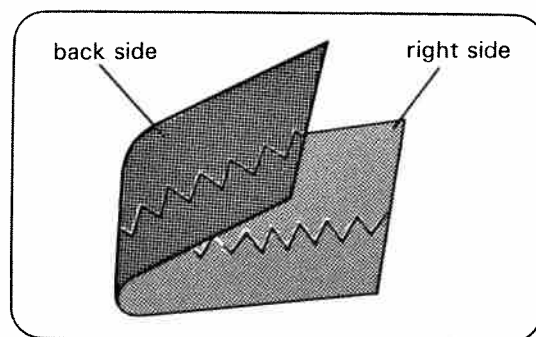

## 7. MAKING BUTTONHOLES

Set machine as shown.

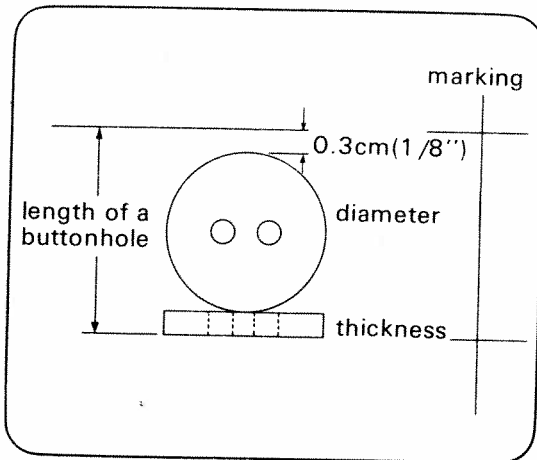
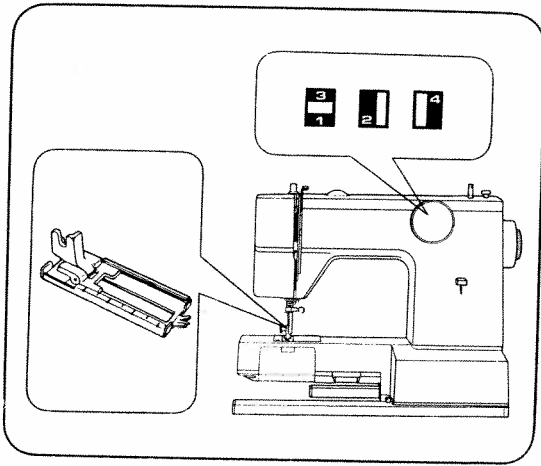

### Determine Length

Measure diameter and thickness of button and add 0.3cm (1/8") for bar tacks.

Mark buttonhole size on material.

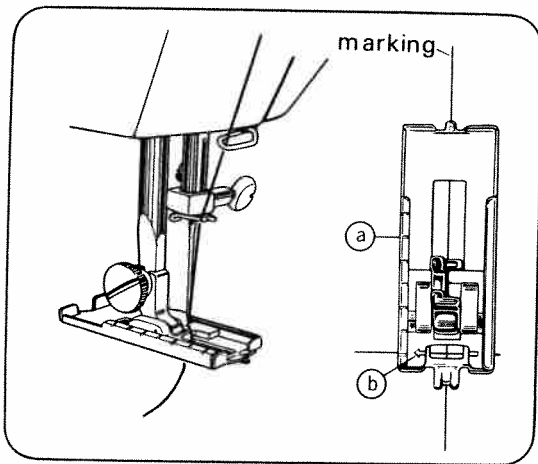



Attach buttonhole foot.

Completely push back sliding part (a) of buttonhole foot.

Place material under foot so that marking of buttonhole passes through center of foot and arrow (b) of foot indicates beginning line of marking.

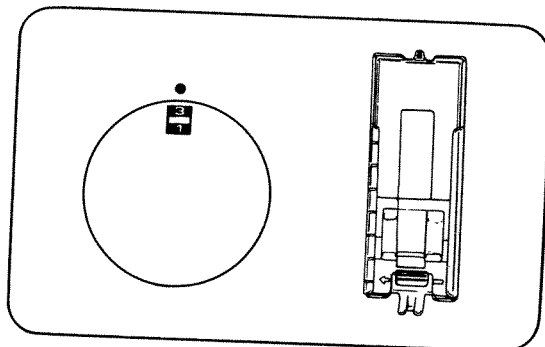
**Bar tacking:** Set pattern selection dial to 1 (  ) and sew 5-6 stitches.



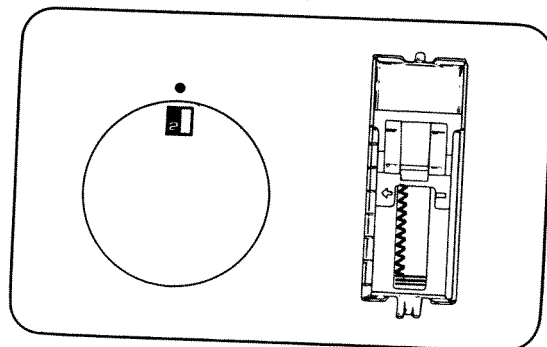

**Left side:** Change pattern to 2 (  ). Sew left side from front to back until it reaches end line.

Remember the point where arrow shows so that it is not necessary to mark end lines for all buttonholes.

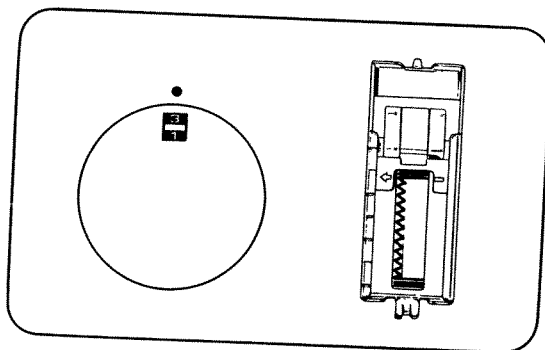

**Bar tacking:** Change pattern to 3 (  ) and sew 5-6 stitches.



**Right side:** Change pattern to 4 (  ) and sew right side until it catches first bar tack.

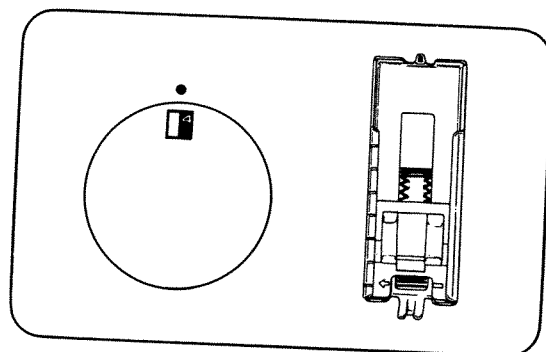

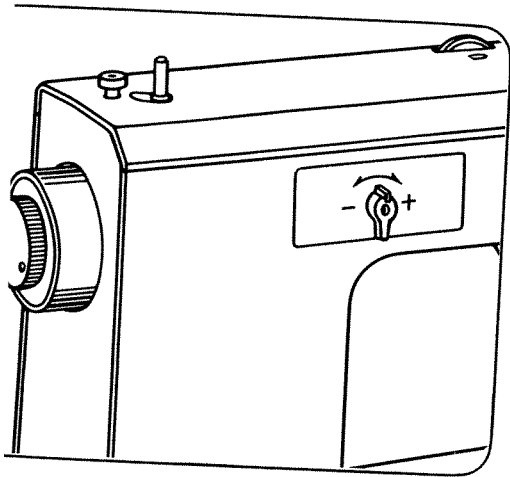

### Left and Right Side Balance of Buttonhole

Stitch density on right and left sides of buttonhole can be adjust by buttonhole balance control dial.

This dial should usually be in a neutral position (between "+" and "-")

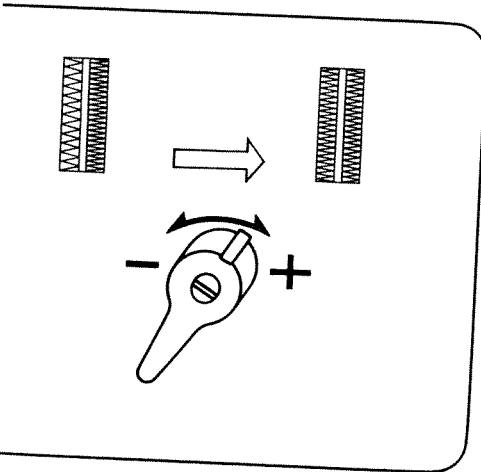

If the stitches on the right side of the buttonhole are too close together, turn the dial to the right (+).

\*Turning dial to right opens right side and closes left side.

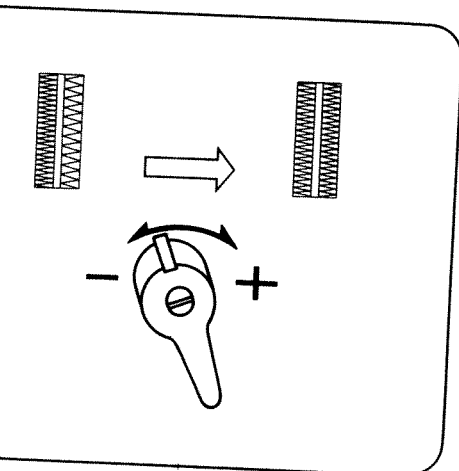

If the stitches on the right side of the buttonhole are too open, turn the dial to the left (-).

\*Turning dial to left closes right side and opens left side.

#### Note:

This dial can simultaneously adjust stretch stitch balance. Therefore please refer to page 31 when you move this dial.

### Cutting Buttonholes

Stick a needle through bar tacks to prevent over-cutting.

Cut buttonhole along center with buttonhole cutter.

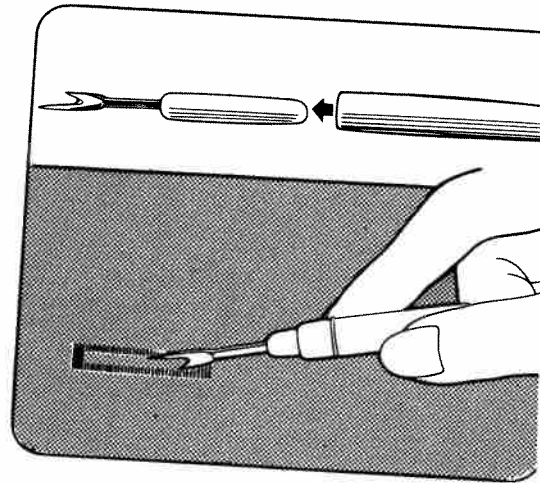

### Corded Buttonholes

For stretch fabrics such as knits, a corded buttonhole is effective to keep finished buttonhole in shape.

Hook filler cord on top spur and lead ends of cord under foot, pull taut, and hook them to bottom notches as shown.

Proceed with stitching as for regular buttonholes.

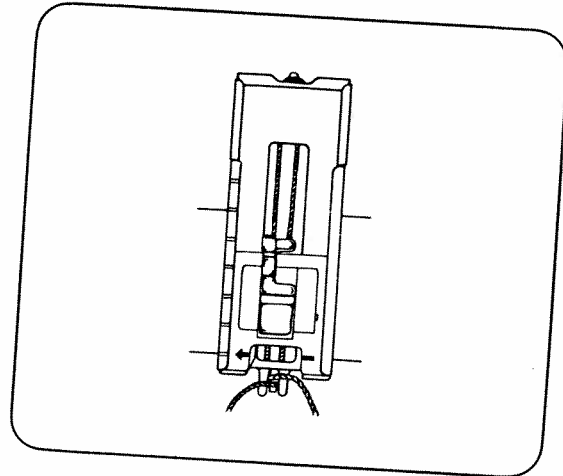

When buttonhole is completed, pull filler cord ends so that loop on the other end disappears into buttonhole stitching.

Thread ends of cord to reverse side and tie, or cut both ends of cord.

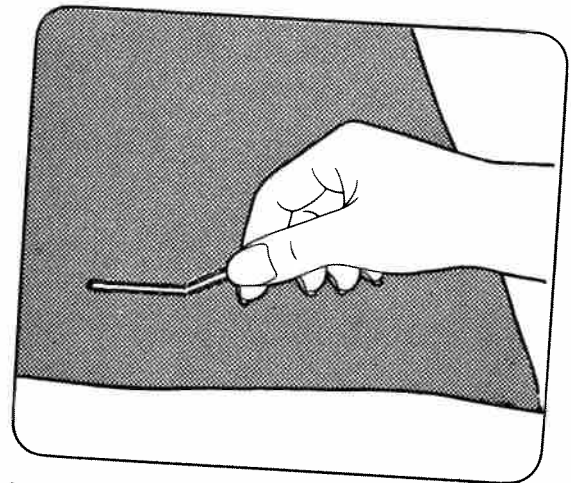

## 8. OVERCASTING

**For light weight material:**  
a ball-point needle is essential.  
Set machine as shown.

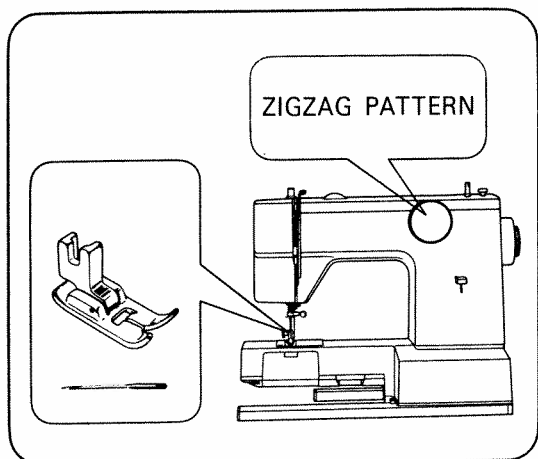

Sew carefully so that all stitches on right side are flush with edge of fabric.

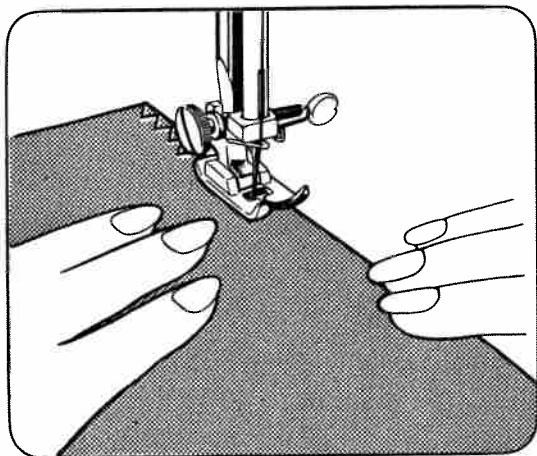

**For thick and elastic material:**  
(For model 1510 and 2640 only.)

Set machine as shown.  
Sew in the same way above.

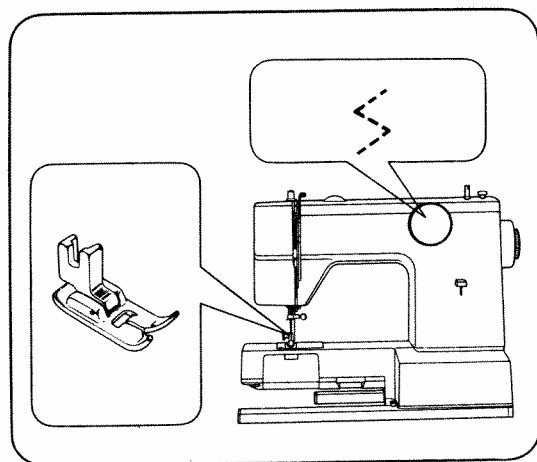

## 9. BLIND HEM STITCH

Set machine as shown.

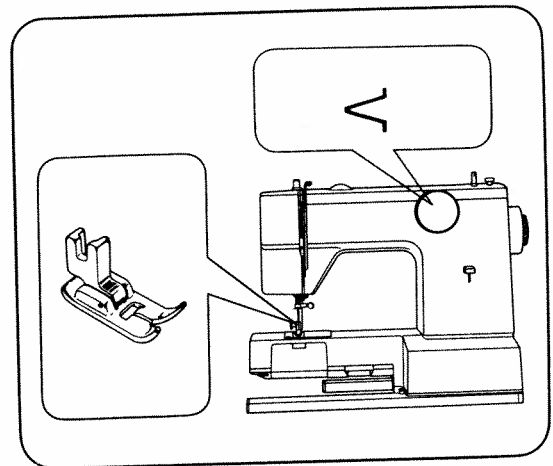

Fold material as shown and place it under foot.

For a neater finish, it is preferable to baste or iron hem beforehand.

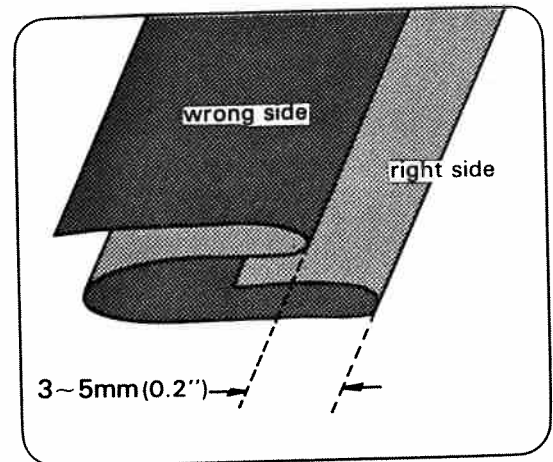

Sew carefully, guiding fold against guide so that straight stitches are made on hem edge, and slanting stitches pierce only one or two threads of fold.

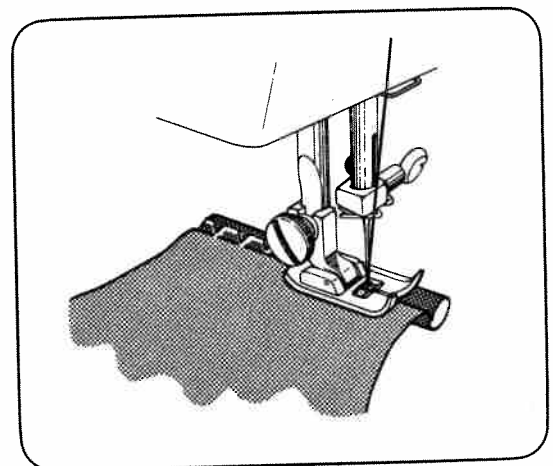

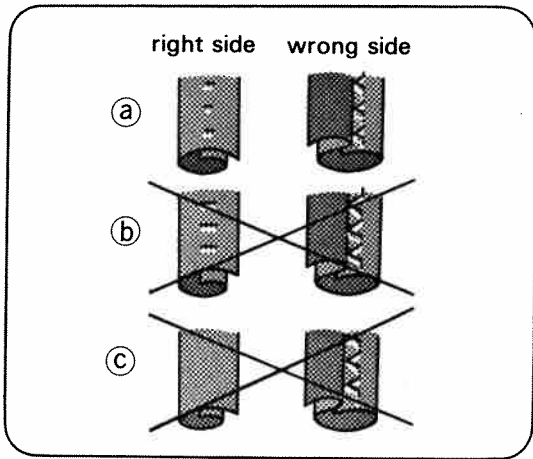

- Ⓐ Correct seam.
- Ⓑ Needle is catching edge of fold too much.
- Ⓒ Needle is not catching edge of fold at all.

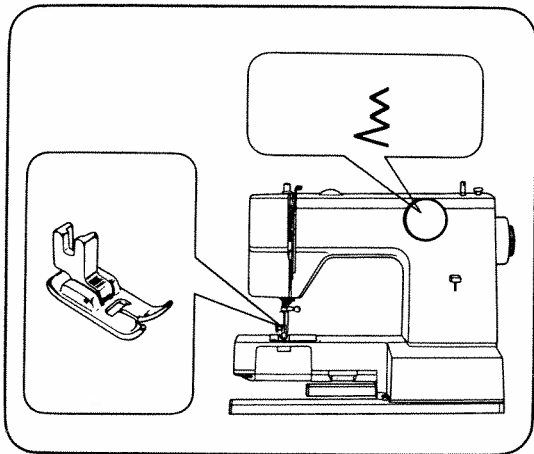

**Elastic Blind Hem Stitch**  
 (For model 1510 and 2640 only.)

For elastic materials, set machine as shown and sew in the same way as for normal blind hem stitch.

## 10. SHELL STITCHING

Silk, nylon organdy or similar sheer fabrics are suitable.

Set machine as shown.

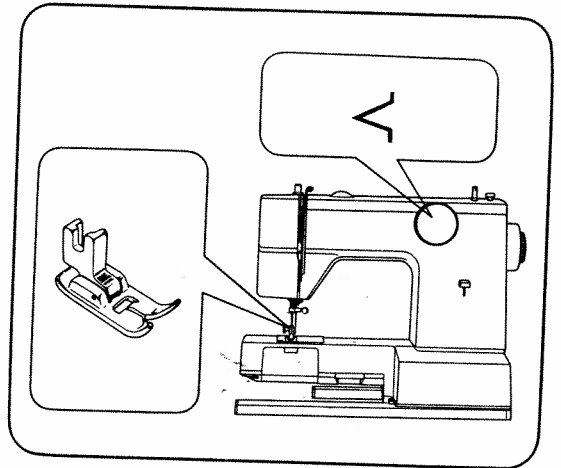

Fold edge of material. With folded edge to left, place it under presser foot.

Pull thread ends towards back when starting sewing.

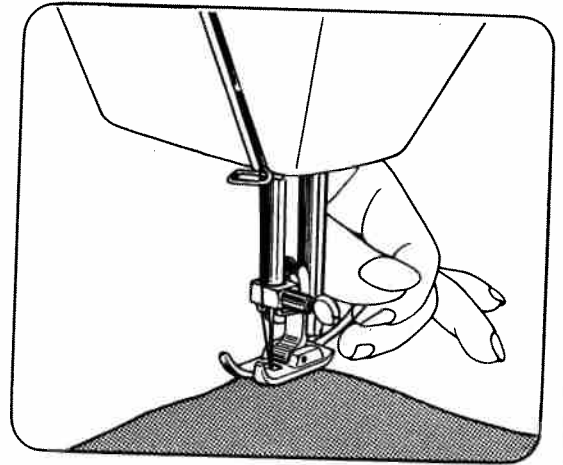

Make sure needle misses raw edge of fold when it moves side ways.

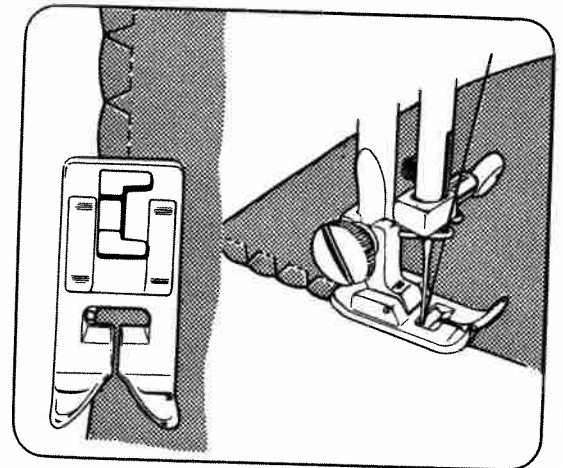

## 11. MENDING

### Patching

(For model 1510 and 2640 only.)

Set machine as shown.

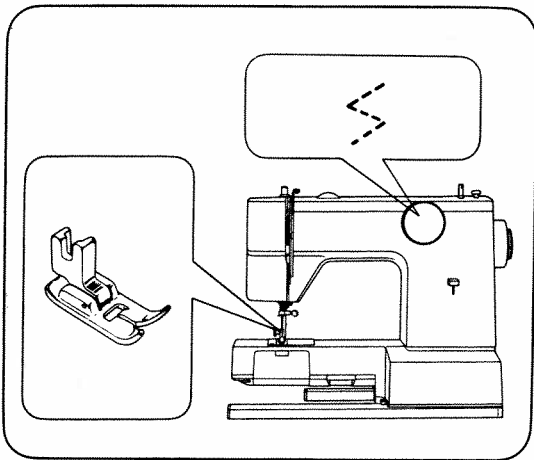

Place the patch over the worn part.

Sew along the edge of the patch on the right side. Trim away the worn part close to the seam on back side.

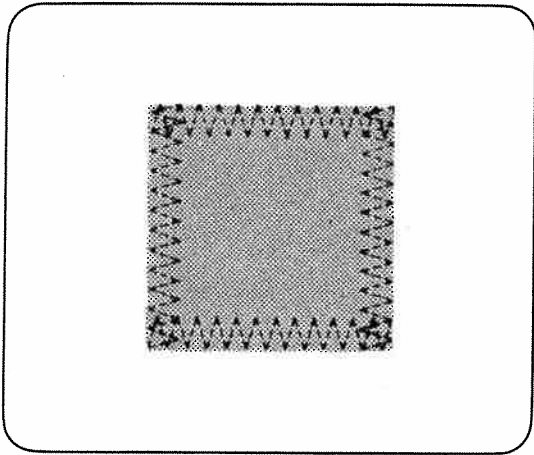

### Mending a Rip

(For model 1510 and 2640 only.)

Set machine in the same way as for patching.

Sew the edges of tear together first.





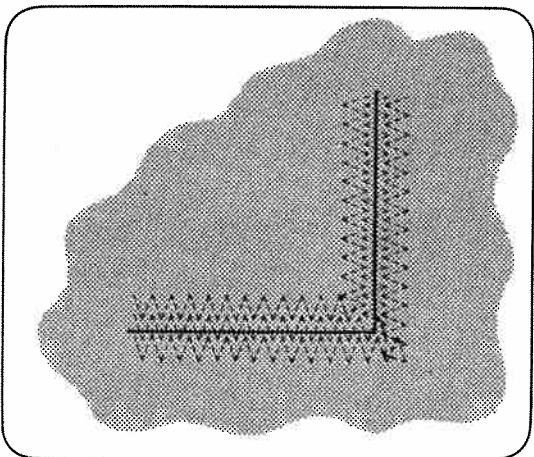



Then sew two more seams on either side.

A piece of gauze can be placed underneath to reinforce the rip.



## 12. STRETCH STITCHING

The stitches shown are all used with stretch and knit fabrics. These are special stitches built in the machine for your quick selection.

-  Straight stretch
-  Rickrack briar stretch
-  Briar stretch
-  Feather stretch
-  Overcast stretch
-  (   For model 1510 and 2640 only.)

### Adjusting Stretch Stitch Balance

In stretch stitch sewing, the stretch stitch adjuster should usually be in a neutral position (between "+" and "-"). When sewing some fabrics, you may need to adjust this control to balance the stitches for appearance sake.

If design seems open like the illustrations to the left, adjust the control slightly toward "-" until design looks like the center design.

If the design appears to be closed as in the right hand illustrations, turn the control toward "+" until stitching is as you desire.

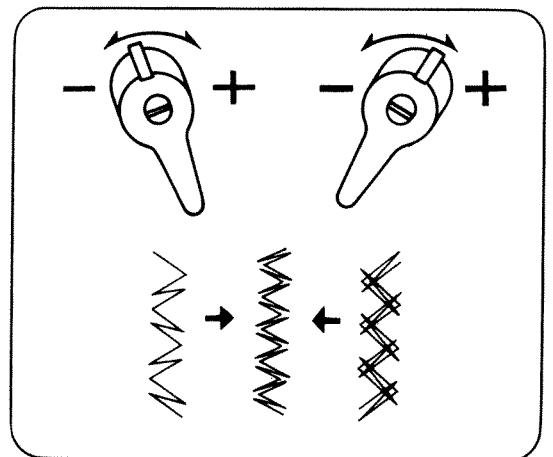
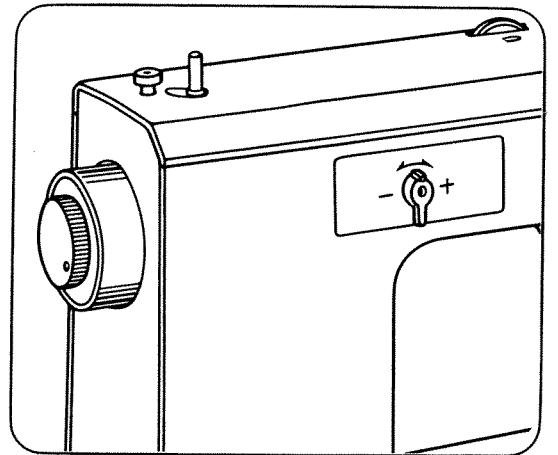
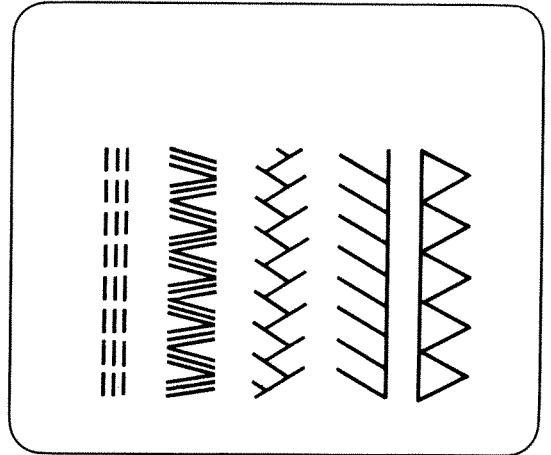

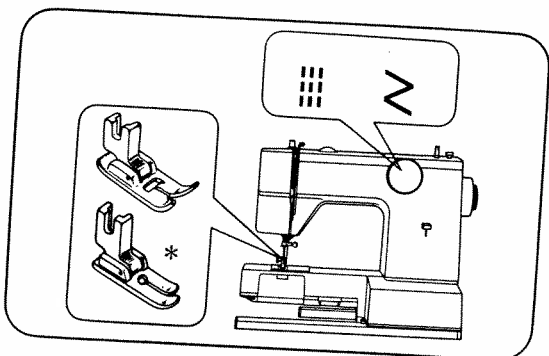

### 13. STRETCH SEAMS

( > For model 1510 and 2640 only.)

Set machine as shown.

\* Option accessory.

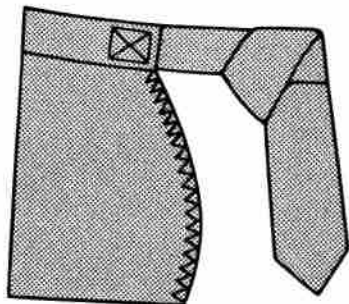
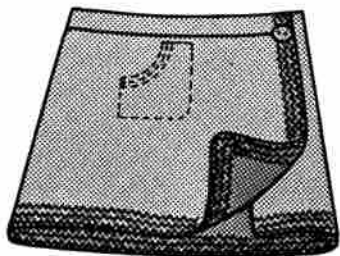
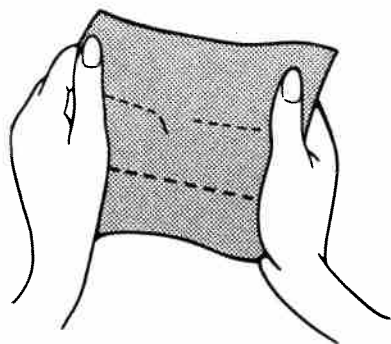

#### Straight Stretch Stitching

Use this stretch stitch with knitted fabric and other fabrics that stretch. Sew as you do with regular straight stitch seaming. The seam may be pressed open as with any regular seam, but will stretch if necessary.

This is also a good stitch to use on curved seams regardless of the type of fabric. Any seam that will receive a great deal of strain when worn should be sewn with the stretch stitch. Use in children's shorts and slacks as well as adult sports clothes.

#### Rick-Rack Stretch Stitching

(For model 1510 and 2640 only.)

Sew on stretch fabrics in any area that you might use a zigzag stitch.

This stitch can be used as a decorative top stitch as well.

## 14. LAPPED SEAM SEWING

(For model 1510 and 2640 only.)

Set machine as shown.

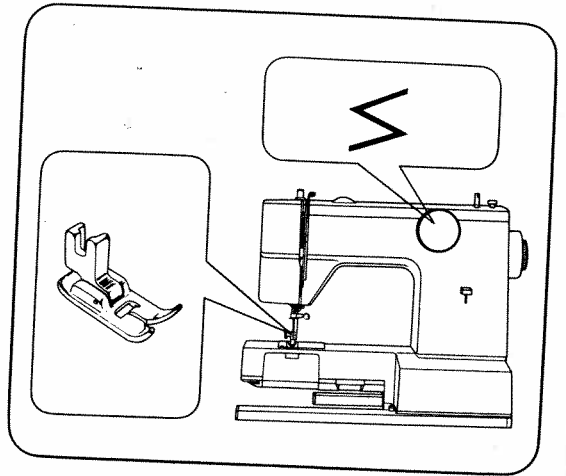

Place one piece of fabric over another according to the width of stitch size.

- Ⓐ For non-fray fabrics.
- Ⓑ For easy to fray fabrics.

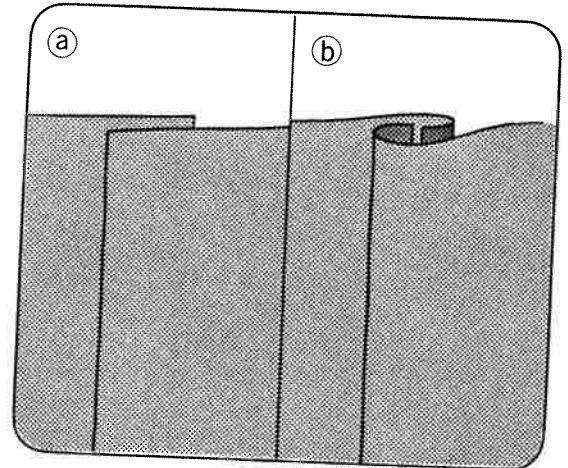

Sew over folded area from right side.

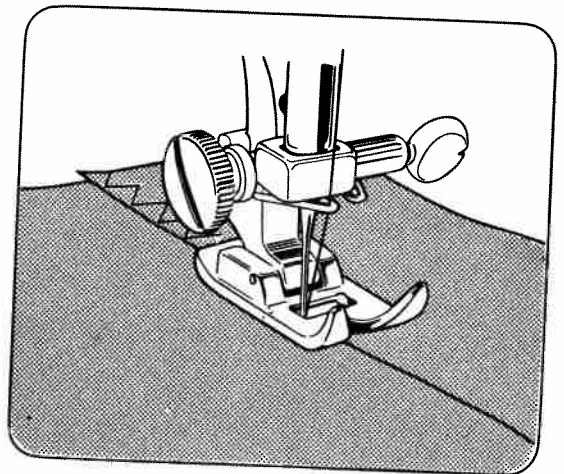

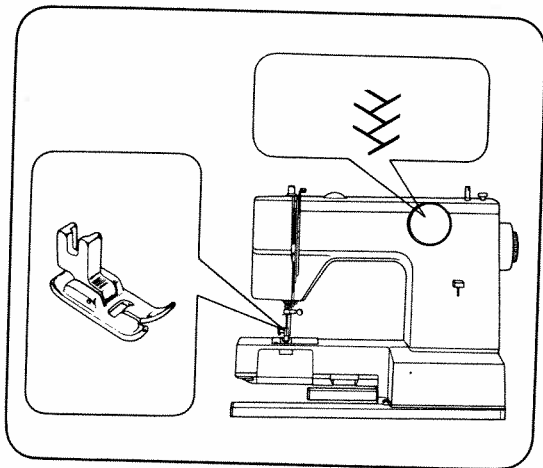

**15. BRIAR STRETCH**  
(For model 1510 and 2640 only.)

This stitch can be used as a decorative stitch on household lines and clothes for children.

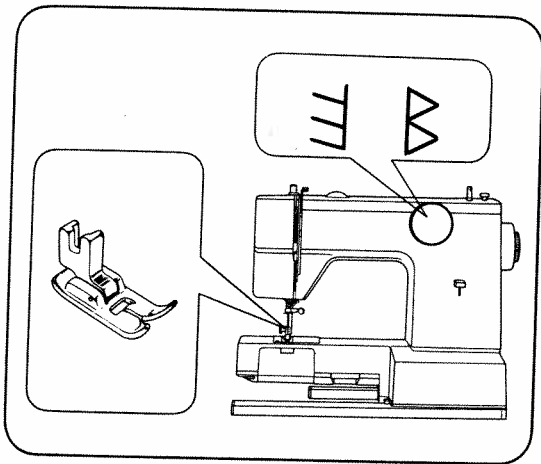

**16. OVERLOCKING**

( For model 1510 and 2640 only.)

Overlocking stitches make it possible to sew and overcast seams at the same time.

Set machine as shown.

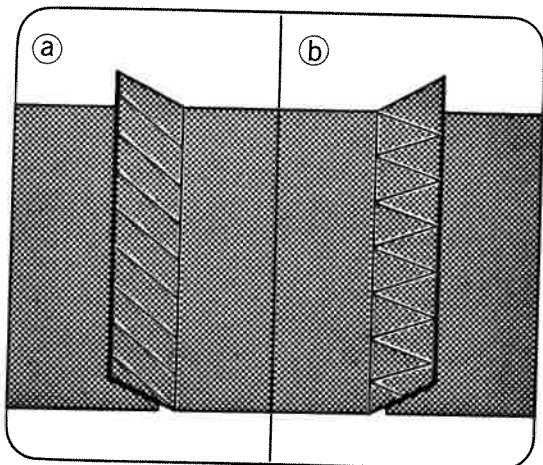

Put two pieces of cloth together with right sides facing and sew.

To prevent edges from fraying, sew so that right side stitches drop outside the edge of material.

In some cases overlocking stitches can be used for overcasting.

## 17. SEWING ON BUTTONS

Set machine as shown.

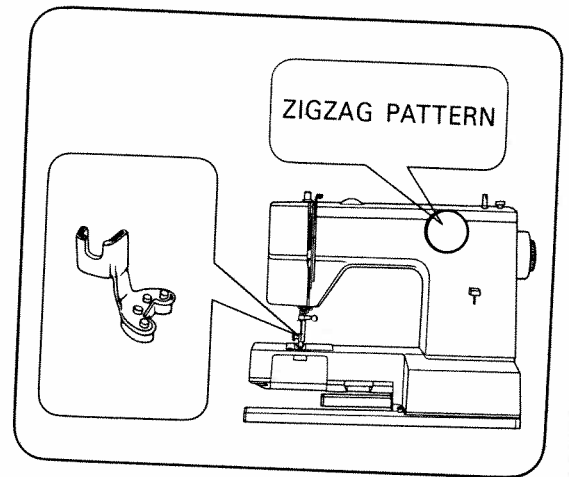

Attach darning plate on needle plate. (See page. 13)  
Select Zigzag width to suite the size of the button from pattern No. 8, 9, and 10.

**\* No.11 for model 1510 and 2640 only.**

Place a button and material under foot.

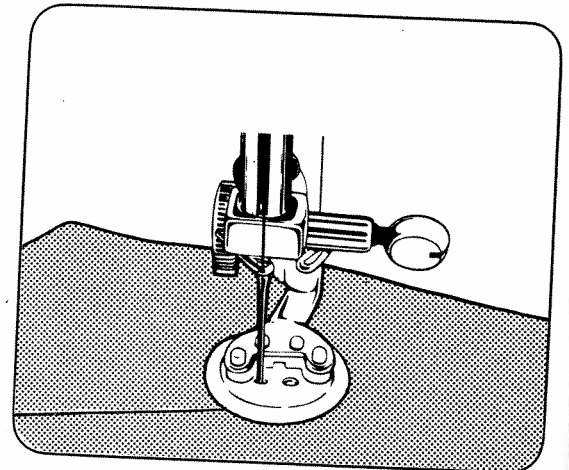

Sew 5-6 zigzag stitches.  
Stop machine when needle is in upper position.

Draw out work and cut off threads.  
Draw thread ends through to wrong side and tie a knot.

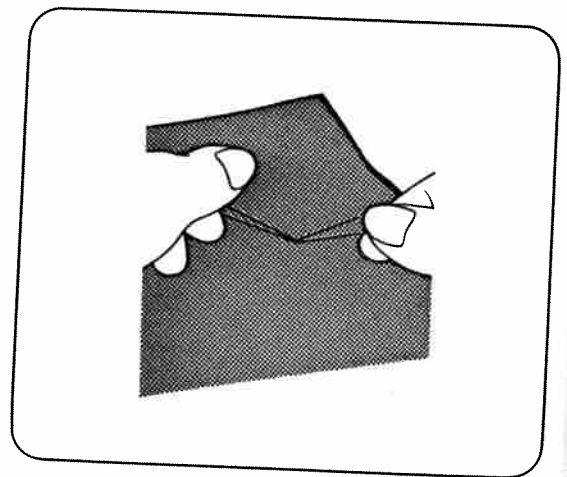

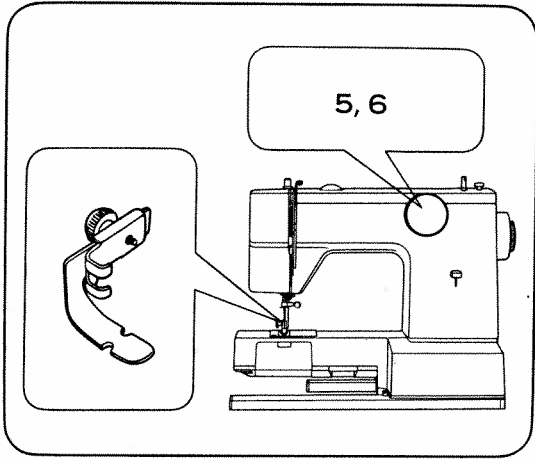

## 18. ZIPPER SEWING

Set machine as shown.

By using special zipper foot with sliding adjuster, zipper sewing can be easily done without turning fabric.

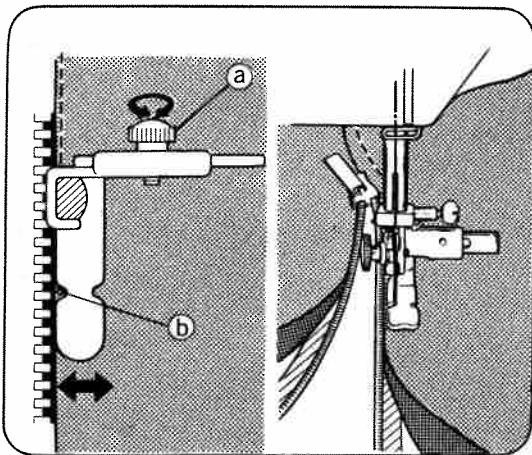

Loosen screw (a) and set foot so that needle comes into position (b). Tighten screw.

Sew right side of zipper guiding fabric carefully so that right side teeth of zipper are parallel with left edge of foot.

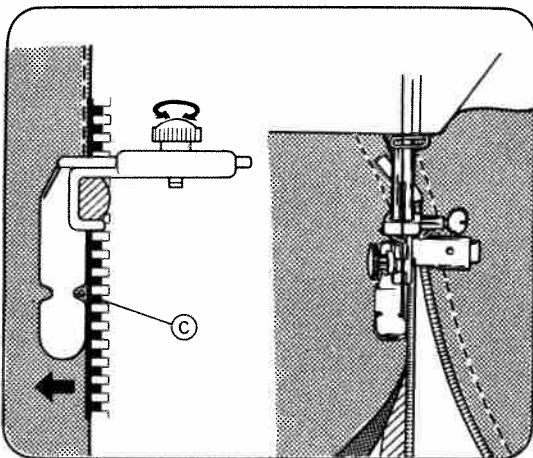

Re-set foot so that needle comes into position (c).

Sew left side of zipper in the same way.

## 19. ROLL HEMMING

Set machine as shown.

\* Option accessory.

With straight stitch

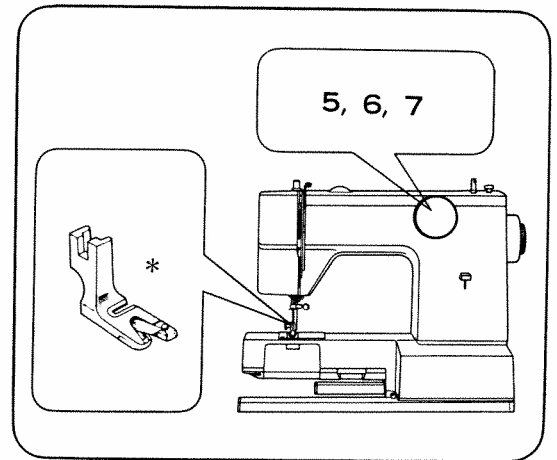
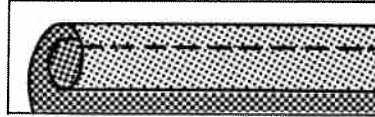

Make 0.3cm(1/8") double fold for about 5cm(2") at very edge of material, and crease it.

Sew twice at 0.6cm(1/4") from edge.

Draw out work and leave about 15cm(6") of thread.

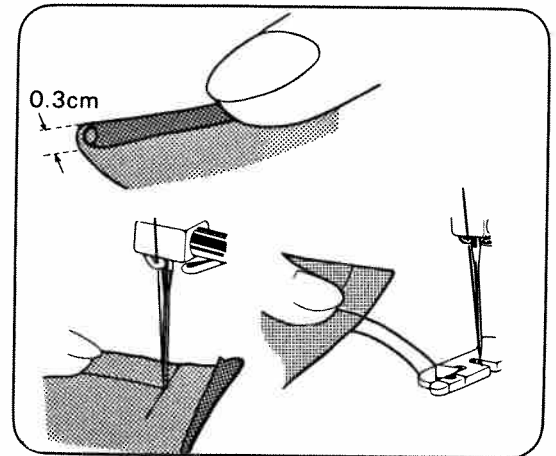

Place material under presser foot and guide edge into scroll, pulling six thread ends towards back. Sew a few stitches as shown. Keep guiding material holding raw edge about 0.6cm(1/4") in front of foot.

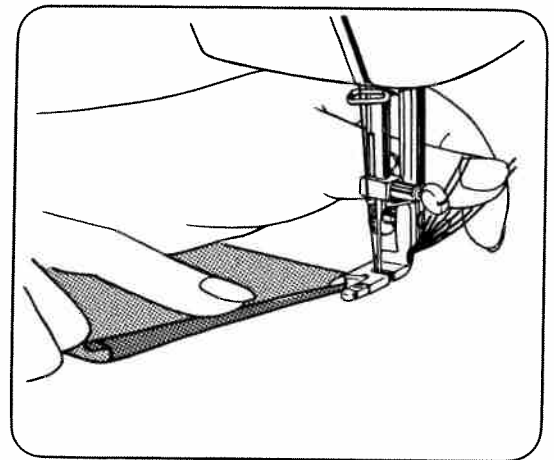

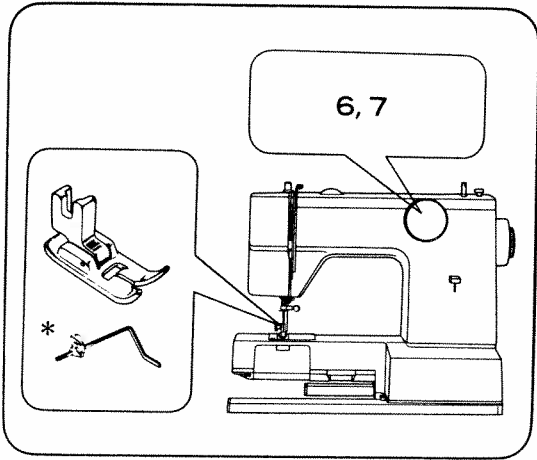

## 20. QUILTING

Set machine as shown.

\* Option accessory.

Baste layers of material to prevent them from slipping out as you sew.

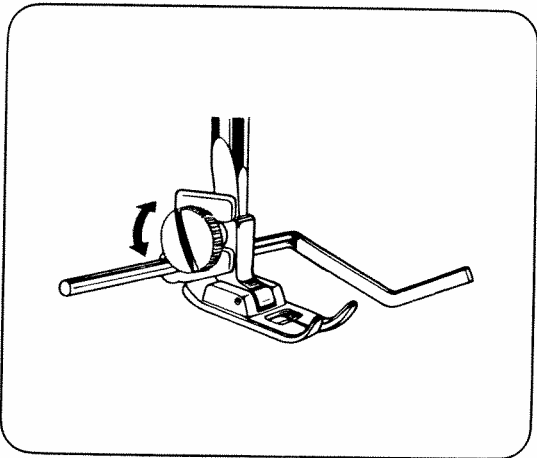

Loosen presser foot thumb screw and insert square cut of quilting guide holder between screw and foot.

Tighten screw.

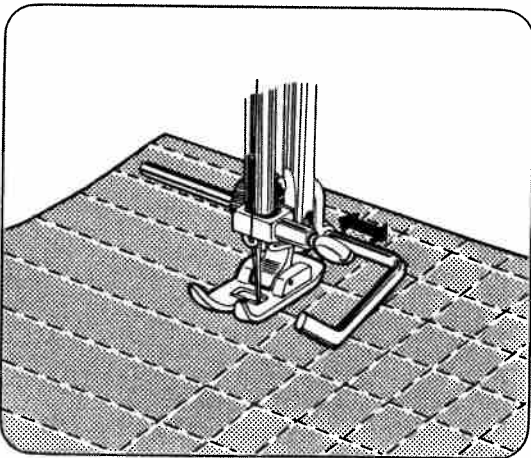

Mark first line with pencil or tailor's chalk, and sew.

From second line, just sew, following seam of first line using guide.

Interval between seams can be adjusted by moving guide in direction of arrow.

## 21. EMBROIDERY

Set machine as shown.

Remove foot, and holder screw.

To avoid lower thread being pulled up, reduce upper thread tension.

For good embroidery, it is important to use correct needles and thread.

Use thin embroidery silk for upper thread and a thinner silk of same kind and color for lower thread.

Trace your design on material and center it in embroidery hoop. Make sure material is taut.

Pull out lower thread by turning handwheel towards you while holding upper thread lightly.

Lower presser foot lifter.

Hold both threads and start sewing along outline of design with satin stitch.

Continue sewing guiding hoop by hand.

To finish filling, sew several stitches with zigzag width at 0.

(Pattern selector dial...No.5, 6, 7)

Lay typewriting paper underneath when embroidering sheer fabric.

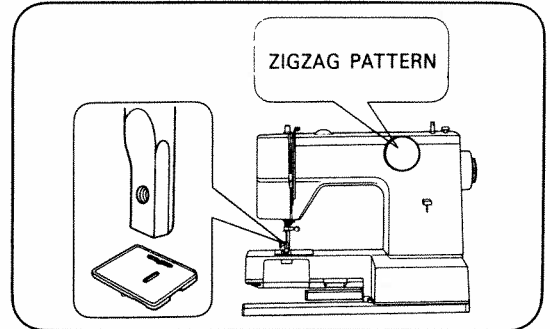

Needle	Thread
No. 9	120~100
No. 11	100~80
No. 14	60~50

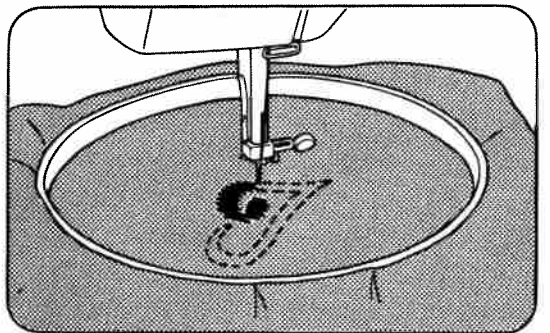
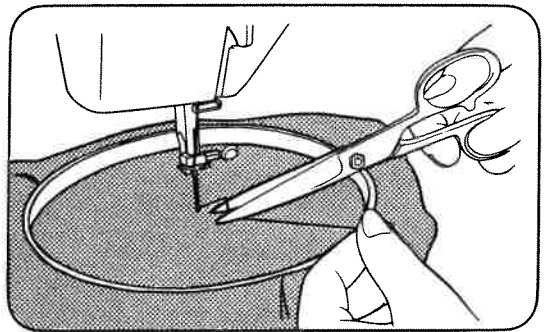

## 22. MAINTENANCE

Your machine requires regular cleaning and oiling for satisfactory sewing performance.

A machine which is used for a few hours a day needs to be cleaned and oiled once a month.

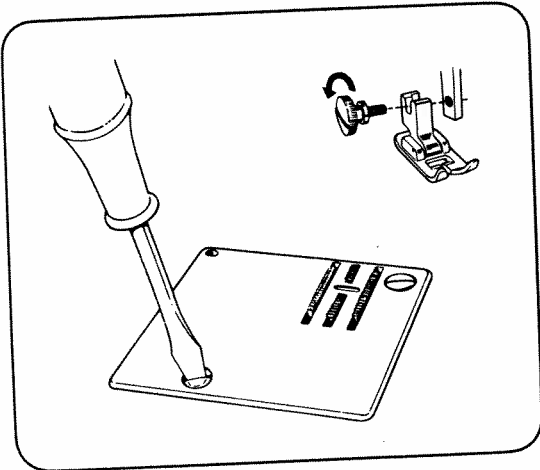

### Cleaning

Remove foot and needle.  
Remove needle plate.

Brush off all dust and lint on feed dog with cleaning brush.

Turn latches outwards.

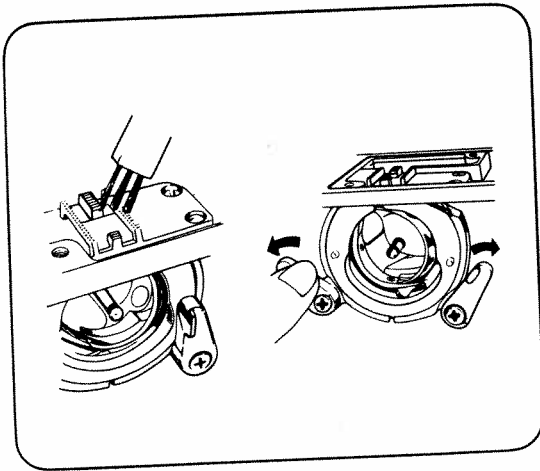

Remove hook race cover.  
Remove hook. Clean hook race with a cleaning brush and a soft cloth.

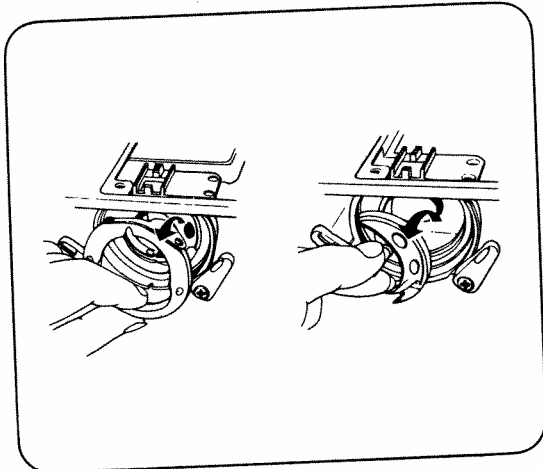

## Oiling

Use oil manufactured specially for sewing machine use. Other oils will eventually cause mechanism to jam.

Apply one drop of oil to part of hook where friction occurs.

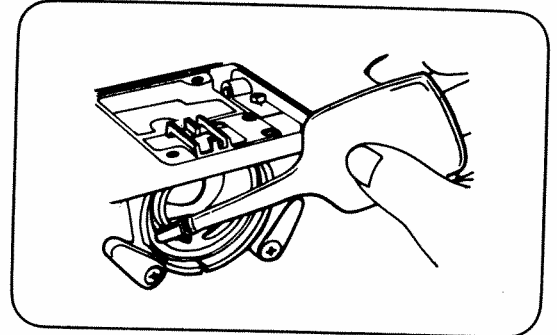

Open face cover and apply oil in the same way.

Be careful not to apply too much oil or it may stain your material and cause some sewing difficulty.

After oiling, run machine for 1-2 minutes to allow oil to penetrate to every part.

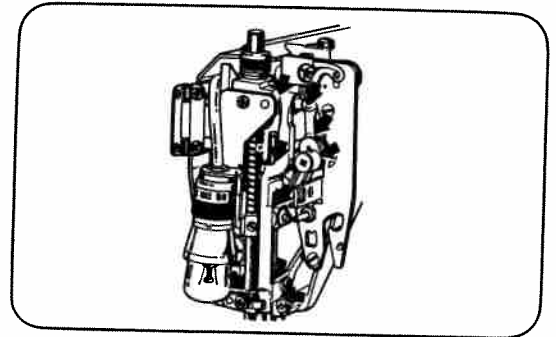

Remove top cover by loosening screws **a** and **b** with large screwdriver.

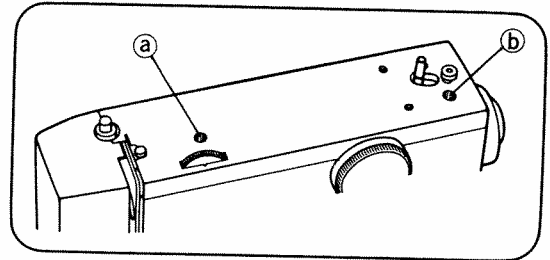

Apply one drop of oil to lubricating points indicated by arrows.

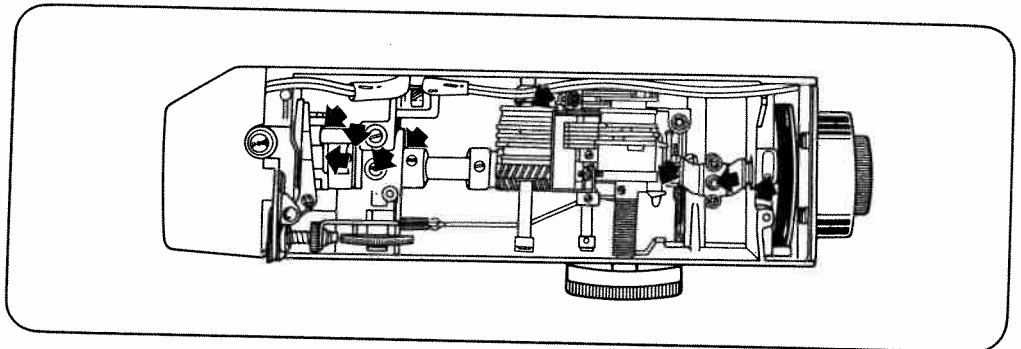

### 23. TROUBLE CHART

PROBLEM	PROBABLE CAUSE	CORRECTION
Breaking lower thread	Thread not wound evenly on the bobbin or not drawn up correctly Lower thread tension too tight Lint stuck in the bobbin case and inside the tension spring	P.11, P.14  P.13 Remove lint and fluff with a cleaning brush
Skipping stitches	Needle not fully inserted Needle bent Size or type of needle and thread not suitable for the material Incorrect upper threading Too much oil on the hook	P. 8 P. 8 P.16 P.14 P.41
Irregular stitches	Incorrect size of needle for the material Upper thread tension too loose Incorrect lower tension	P.14 P.20 P.12
The material not fed correctly	Pattern selection dial not set correctly Lint stuck on the feed dog	P.18 P.40

PROBLEM	PROBABLE CAUSE	CORRECTION
The material puckers	Upper or lower thread tension too tight Stitch too long for material Thread too thick Incorrect threading of upper or lower thread	P.13, P.20 P.18 P.16 P.14, P.12
Breaking needle	Needle not correctly inserted Needle bent Needle clamp screw too loose Upper thread tension too tight Needle too fine for the material Dials have been changed while the needle was down in the material	P. 8 P. 8 P. 8 P.20 P.16 P.18

If trouble is still apparent in the machine, please consult your nearest dealer.  
Do not try to correct fault by yourself.

### Changing Light Bulb

Unplug the machine.  
Open face cover as shown.

Remove bulb by unscrewing it  
in counterclockwise.  
Install a new bulb by screwing it  
in clockwise.

\* In case face cover is fixed by a  
screw, open face cover after  
loosening a screw by screw  
driver.

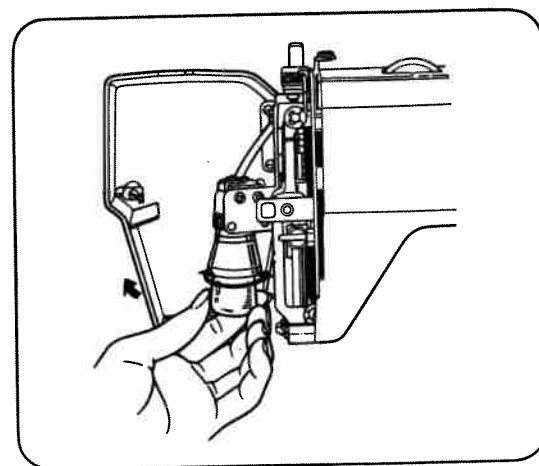

590049-111-E  
Printed in Taiwan