

**SINGER®**

# Five-Thread Safety Stitch Narrow

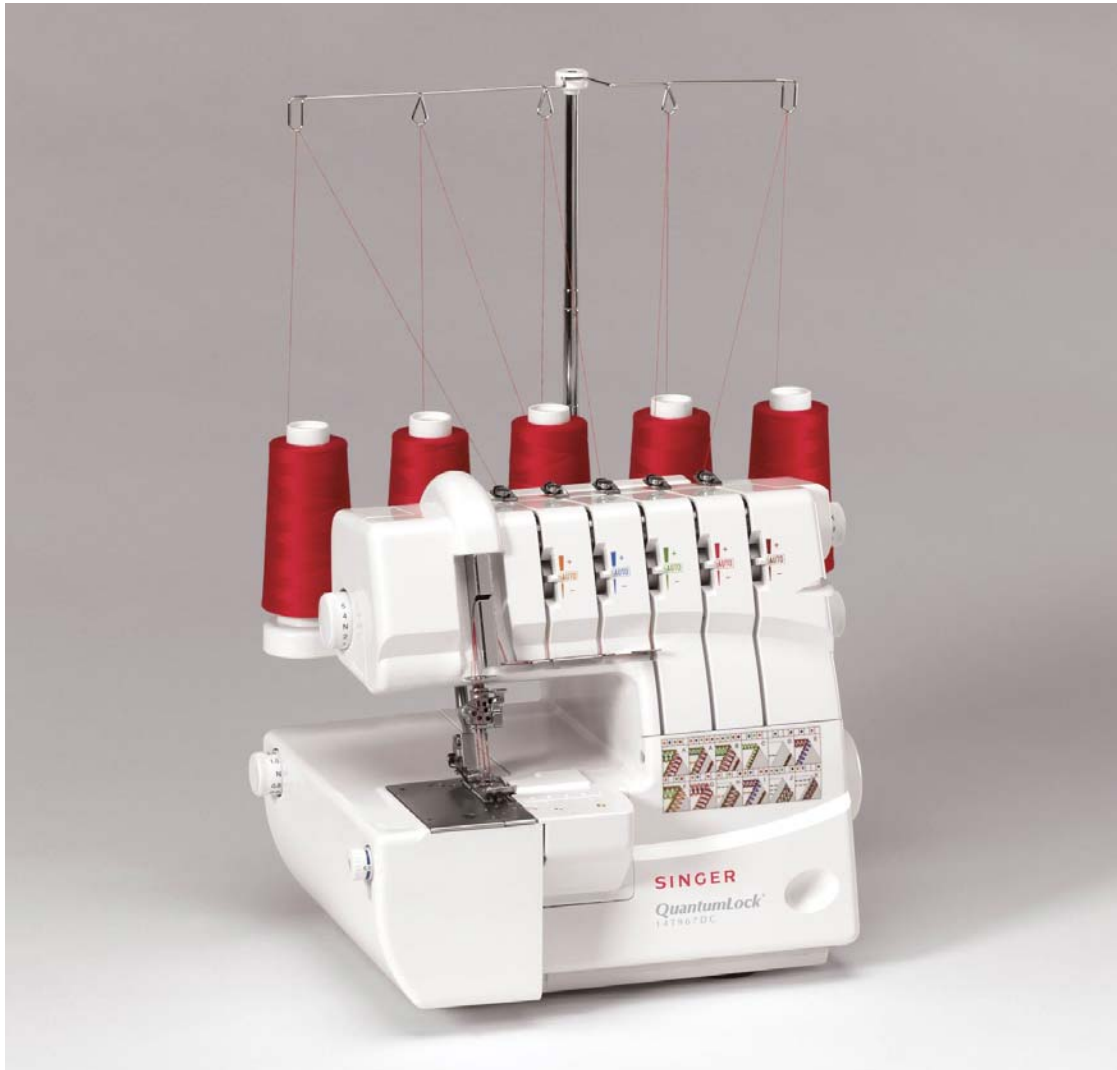

## Five-Thread Safety Stitch (Narrow)

This stitch is a combination of a Two-Thread Chainstitch and a Three-Thread Overlock Stitch. It is suitable for woven fabrics and provides a durable seam for heavy weight fabrics such as denim and terrycloth. Using this strong and stable safety stitch eliminates the need to reinforce the seam with a conventional sewing machine straight stitch. The Pressure Adjusting Dial makes it simple to sew on all weights of fabrics. The Five-Thread Safety Stitch can have a width of 2.8mm or 5.6mm depending on which overlock needle position is chosen.



Hint: Try a wider stitch width (6.5) for thicker fabrics such as Terrycloth.

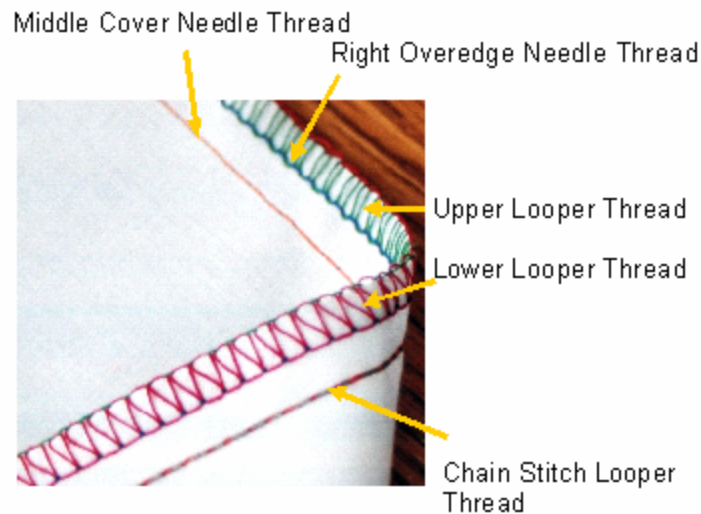

## Set up:

### Needles:

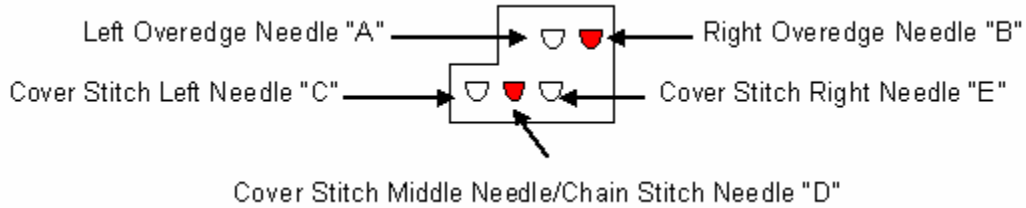

### Set at:

<b>ATD:</b> Auto Tension Dial	"A"
Left Cover Stitch Needle "C"	Not Threaded
Middle Cover Stitch Needle "D" (Orange)	Threaded
Right Cover Stitch Needle "E"	Not Threaded
Overedge Left Needle "A"	Not Threaded
Overedge Right Needle "B" (Blue)	Threaded
Upper Looper (Green)	Looper Engaged and Threaded
Spreader	Disengaged
Lower Looper (Red)	Threaded
Chain Stitch Looper (Brown)	Threaded
Upper Looper Clutch	"L"
Upper Knife	Engaged
Seam Guide Plate	Not Installed Use Knife Cover
Seam Width Dial	"N"
Stitch Length Dial	"N"
Presser Foot Pressure	"N"
Differential Feed Dial	"N"
Stitch Finger	"N"

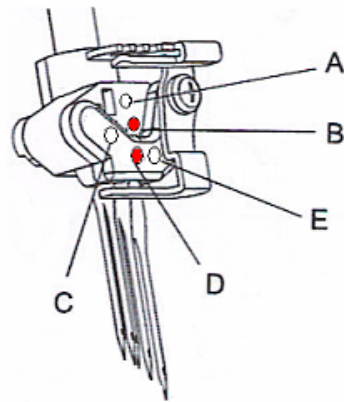

- ◆ Turn Auto Tension Dial to “A”.

- ◆ Turn Stitch Length Dial to “N”.

- ◆ Engage Upper Knife.

The knife will not trim the fabric when it is disengaged.

1. Open Looper Cover.
2. Pull the movable knife holder (silver screw) to the right as far as it will go.
3. Turn the holder clockwise until the knife clicks into a lock position.

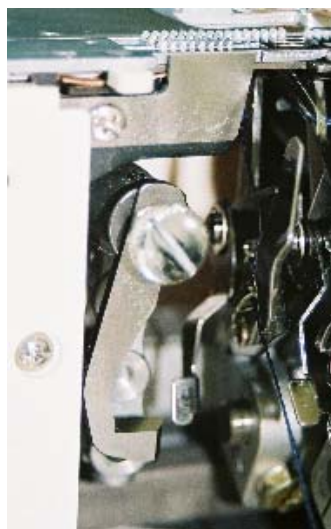
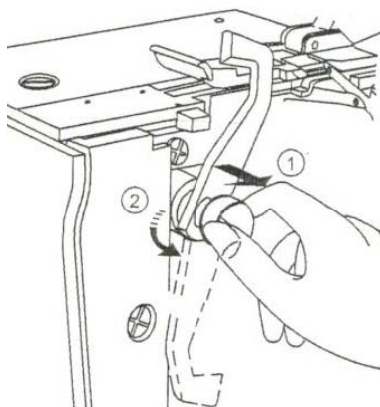

Upper Knife Disengaged



Upper Knife Engaged

# SINGER®

- ◆ Turn Presser Foot Pressure dial to “N”.



- ◆ Turn Differential Feed Dial to “N”.



- ◆ Turn Seam Width Dial to “N”.

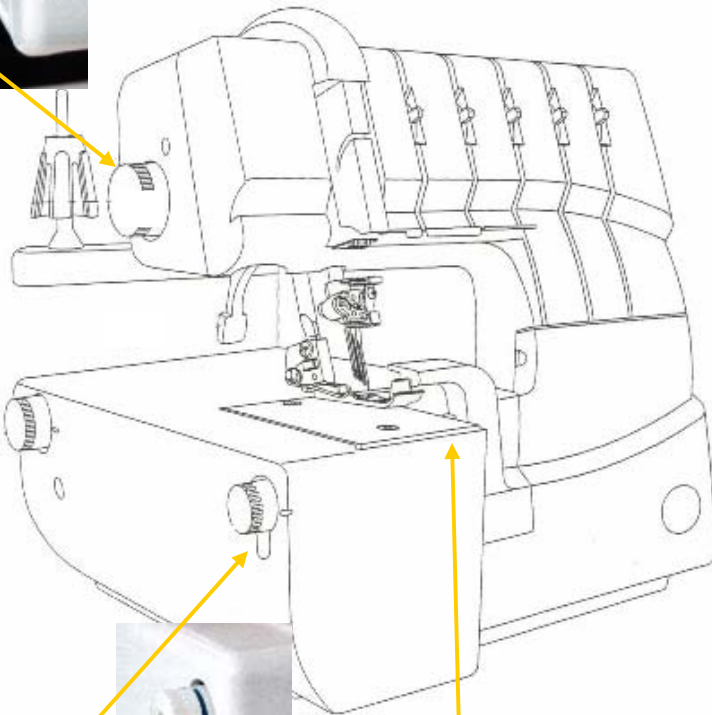

- ◆ Set Stitch Finger to “N”.

◆ Install the Knife Cover.

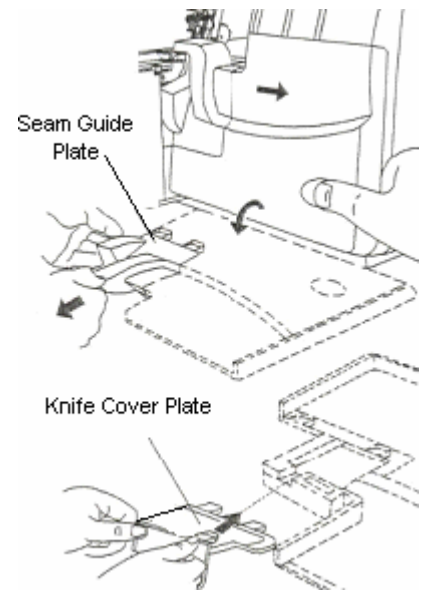

◆ Engage Upper Looper. Engaging the Upper Looper causes the looper to move when sewing. Even though the Upper Looper is not threaded it needs to be engaged.

1. Push the clutch button to the left and down to engage.
2. Turn handwheel.

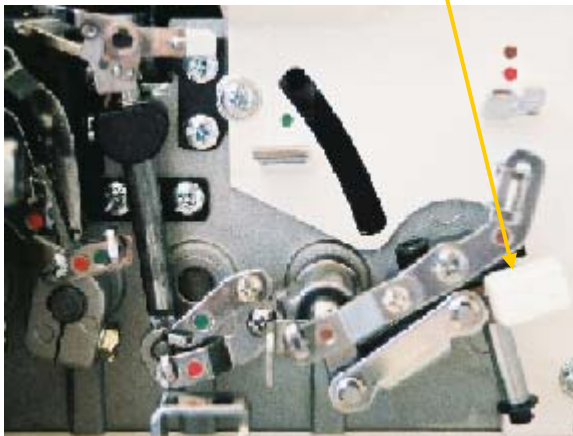
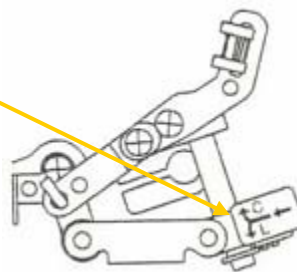

Upper Looper Disengaged

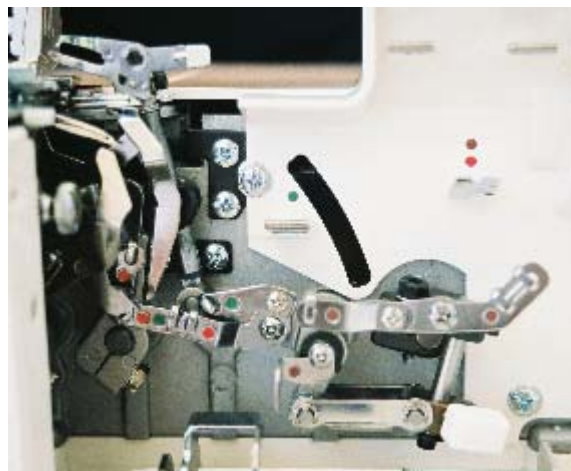

Upper Looper Engaged

- ◆ Disengage Spreader. The Upper Looter has a hole for the thread on the top of the looper. If the stitch requires that the looper be engaged, but not threaded then the Spreader is used. The Spreader simply plugs-in (or closes) the looper's hole. The Spreader is disengaged when the Upper Looter is engaged/operative and threaded. The Spreader is usually used with a stitch that requires only one looper thread. With the help of the Spreader the single looper thread wraps around the fabric's edge.

1. Lower the white handle on the Spreader to open the eye of the Upper Looter.

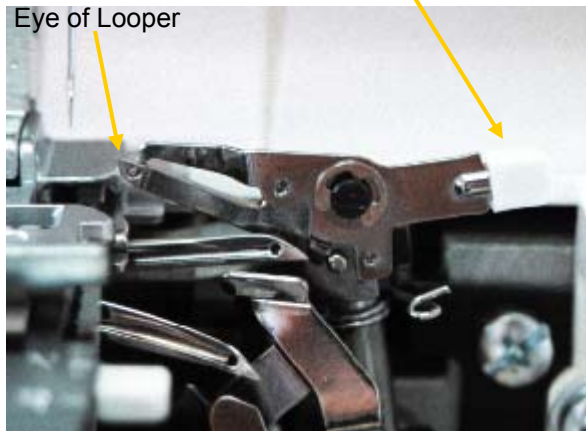

Spreader Engaged



Spreader Disengaged

- ◆ Thread Upper Looter with regular overlock thread.

1. Raise the Presser Foot to release the tension disks. Thread the Lower Looter as illustrated 1-9.
2. Pass thread from back to the front through the thread guide ①.

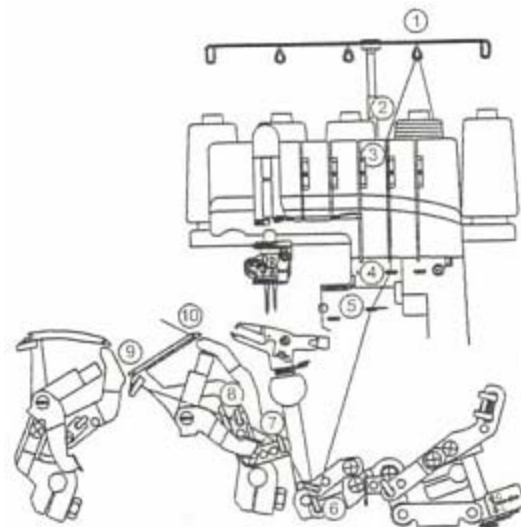
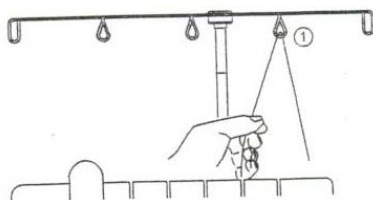

3. Thread the top cover thread guide by pulling the thread towards the left until it slips under the guide. Then pull the thread along the right side of the button as illustrated.

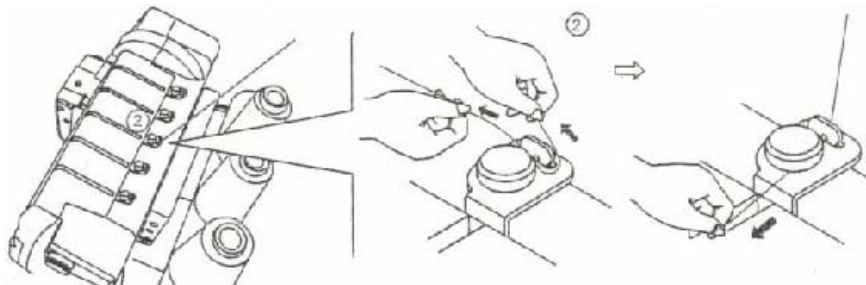

4. While holding the thread firmly, pull the thread between the tension disks.

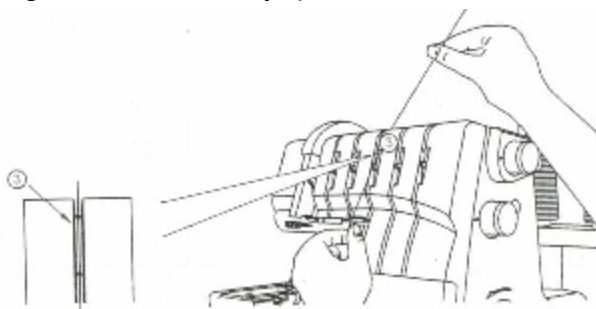

5. Turn the handwheel toward you until the lower looper extends 5-10mm (approximately 1/2 inch) from the needle plate edge.
6. Thread the looper area of the machine following the green color coded thread guides 4-9.

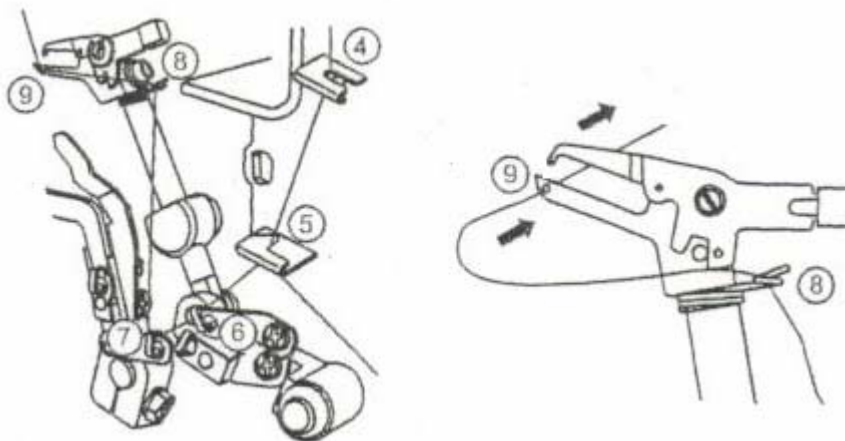

7. Thread the hole in the Upper Looter from front to back ⑨. Pull about 4 inches of thread through the looper and place to the back of the throat plate.

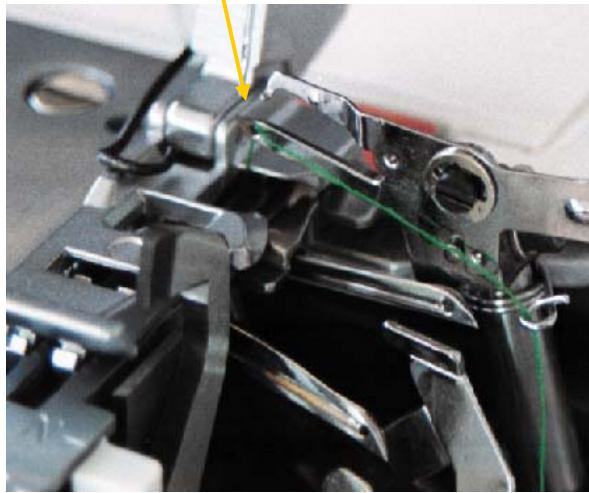

◆ Thread Lower Looter with regular overlock thread.

1. Raise the Presser Foot to release the Tension disks. Thread the Lower Looter as illustrated 1-10.
2. Pass thread from back to the front through the thread guide ①.

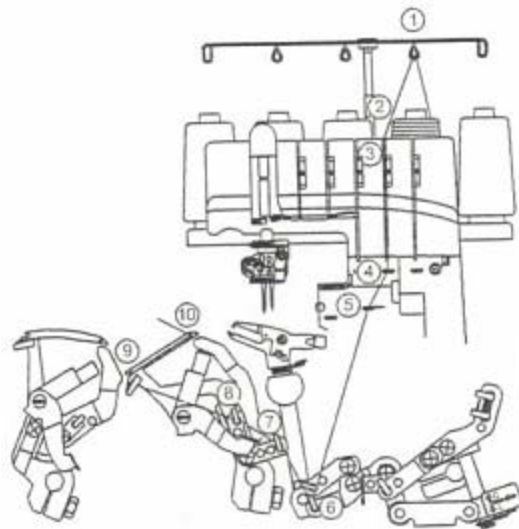
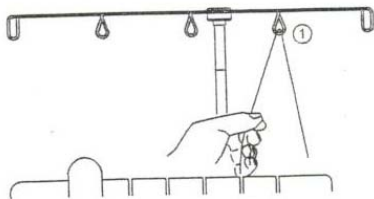

3. Thread the top cover thread guide by pulling the thread towards the left until it slips under the guide. Then pull the thread along the right side of the button as illustrated.

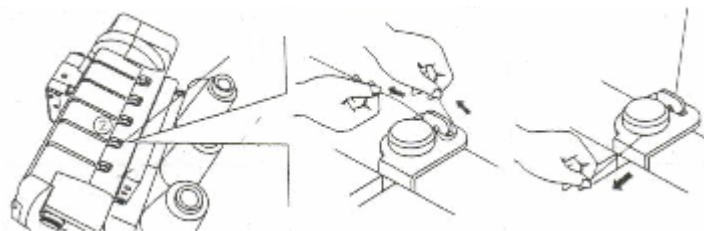

4. While holding the thread firmly, pull the thread between the tension disks.

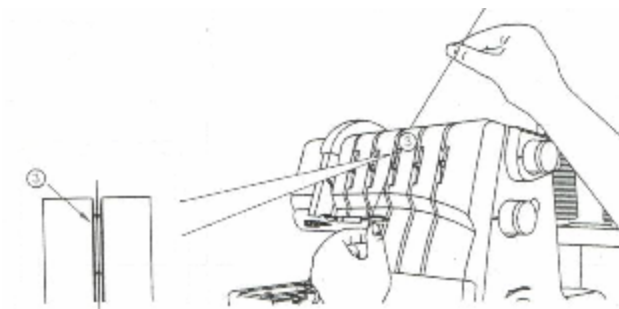

5. Turn the handwheel toward you until the lower looper extends 5-10mm (approximately ½ inch) from the needle plate edge.
6. Thread the looper area of the machine following the red color coded thread guides 4-10.

7. Place the thread slightly from left and to the right of threading guide ④.

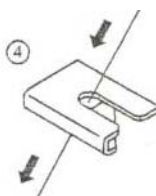

8. Place the thread slightly from the front and to the back of threading guide ⑤.

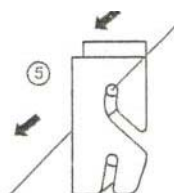

9. Place the thread through ⑥, ⑦ and ⑧.

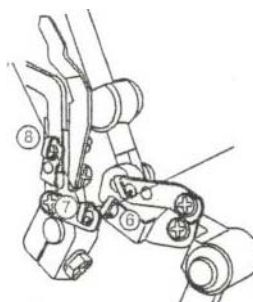

10. Thread the looper eye (A) from front to back. Pull about 4 inches of thread. Position thread into V cutout (B) on threader. Firmly hold thread tail with left hand and pull Threader lever (C) up into place (D).

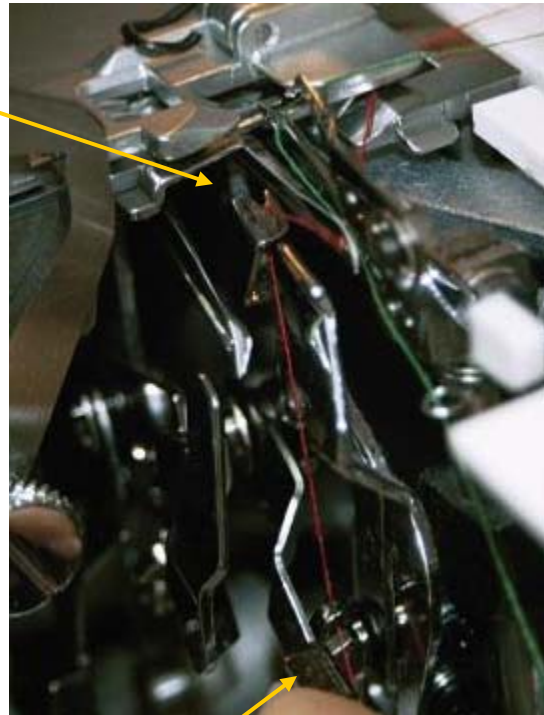
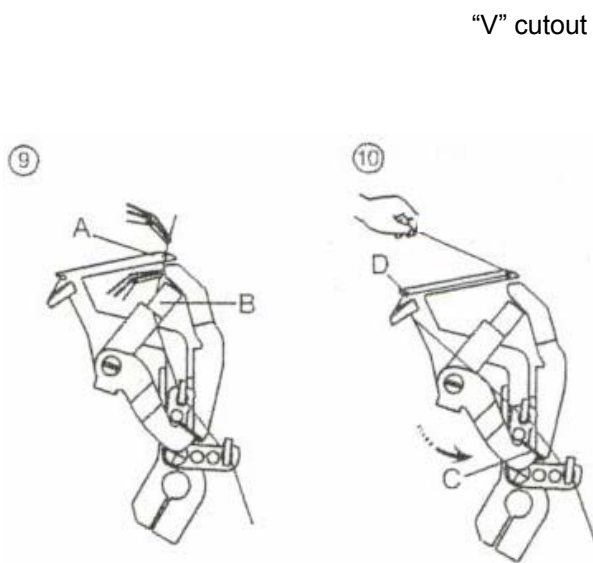

Threader Lever



NOTE: Make sure the Upper Looper thread is behind the Lower Looper thread.

◆ Thread Chainstitch Looper with regular overlock thread.

1. Raise the Presser Foot to release the tension disks. Pass the thread from the back to the front through the thread guide ①.

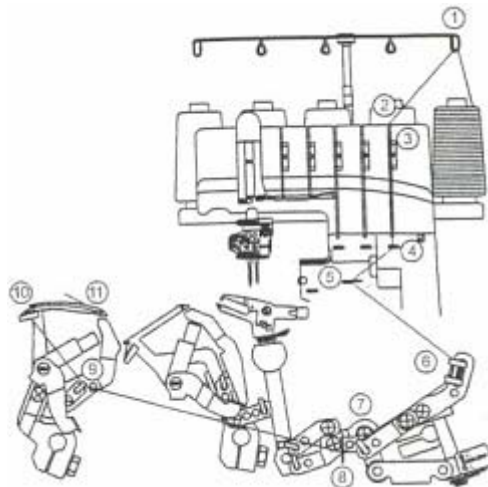
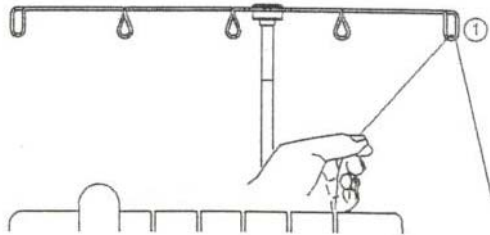

2. Thread the top cover thread guide by pulling the thread towards the left until it slips under the guide. Then pull thread along the right side of the button as illustrated.

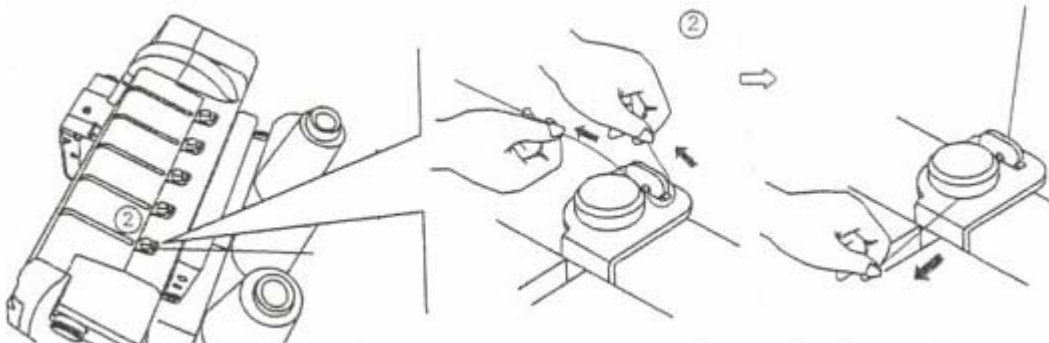

3. While holding the thread firmly, pull the thread between the tension disks.

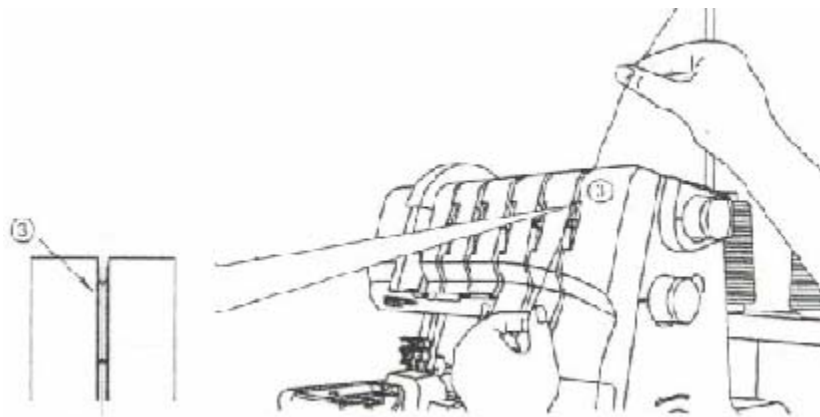

4. Turn the hand wheel toward you until the Chainstitch Looper extends out 10mm (approximately ½ inch) from the needle plate edge.

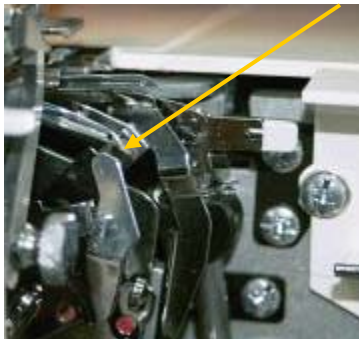

5. Thread the looper area of the machine following the brown color-coded thread guides 4-11. Use the tweezers provided in the accessory case to aid in threading the looper.

6. Place the thread through threading guide ④ and ⑤.

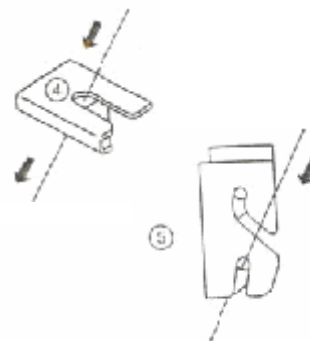

7. Continue threading guides ⑥, ⑦, ⑧ and ⑨.

8. Thread the looper eye (A) from front to back. Pull about 4 inches of thread through the looper. Position the thread into the V cutout (B) on the threader. Firmly hold the thread tail with your left hand and pull threader lever (C) up into place (D). Gently pull 5-6" of thread to the back of the machine.

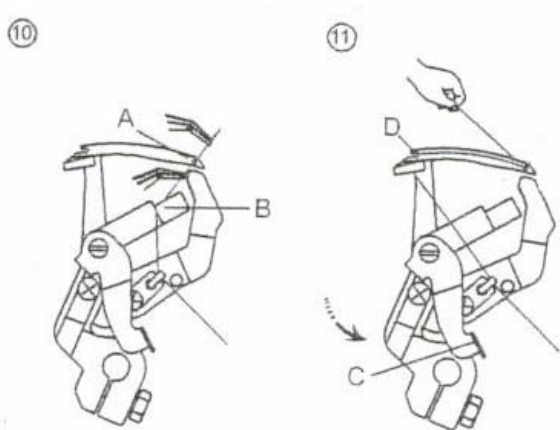

"V" cutout

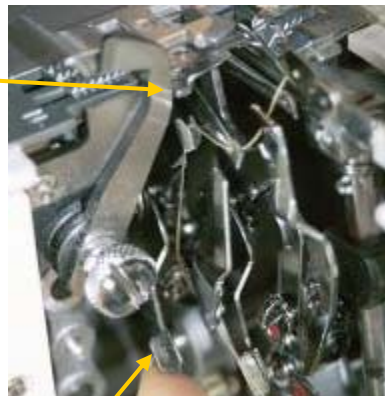

Threader lever

◆ Thread Right Overedge needle with regular overlock thread.

1. Raise the Presser Foot to release the tension disks. Thread the right needle as illustrated 1-9.

2. Pass thread from back to the front through the thread guide ①.

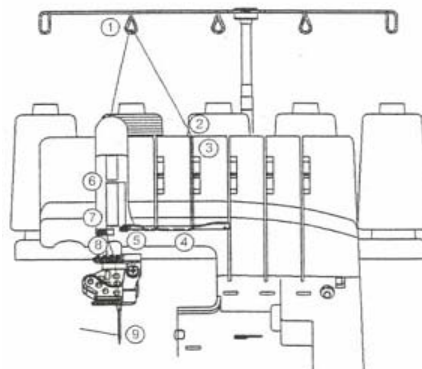
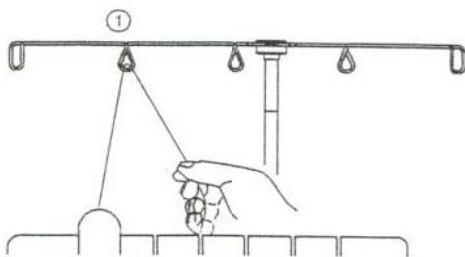

3. Thread the top cover thread guide by pulling the thread towards the left until it slips under the guide. Then pull the thread along the right side of the button as illustrated.

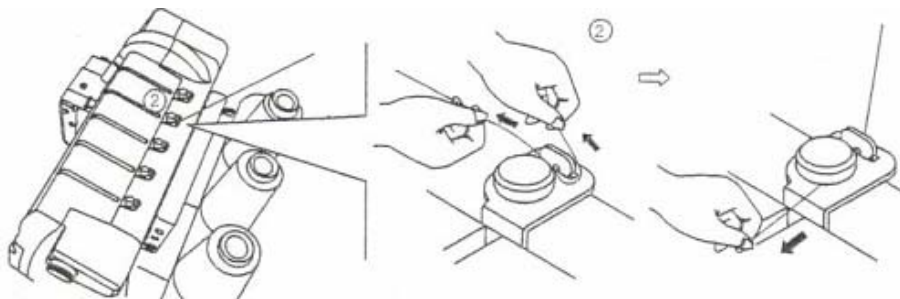

4. Continue to thread points 4-8. Slip the thread into the rear slot of the thread guide ⑤. Go over the take up lever ⑥. Continue by slipping the thread into the right slot of the thread guides ⑦ and ⑧.

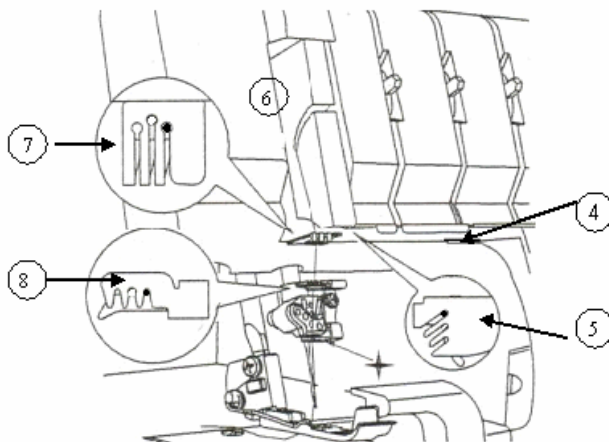

5. Before threading the eye of the needle, make sure the thread is behind the thread guide located on the bottom of the needle clamp.

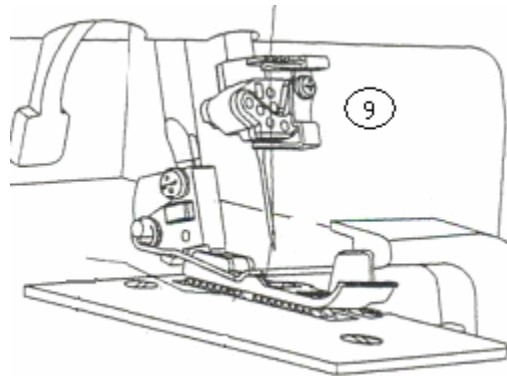

6. Thread the eye of the Right Overedge Needle ⑨.

◆ Thread Middle Cover stitch needle with regular overlock thread.

1. Raise the Presser Foot to release the tension disks. Thread the Cover Stitch Middle/Chain Stitch needle as illustrated 1-9.
2. Pass thread from back to the front through the thread guide ①.

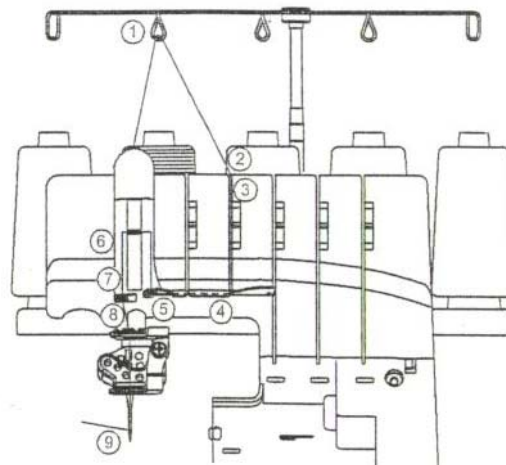

3. Thread the top cover thread guide by pulling the thread towards the left until it slips under the guide. Then pull the thread along the right side of the button as illustrated.

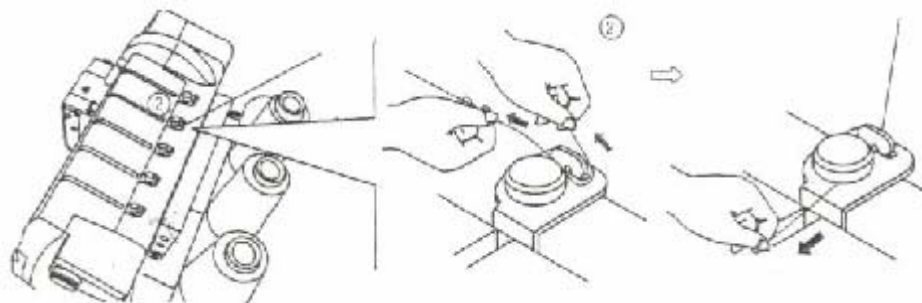

4. While holding the thread firmly, pull the thread between the tension disks.

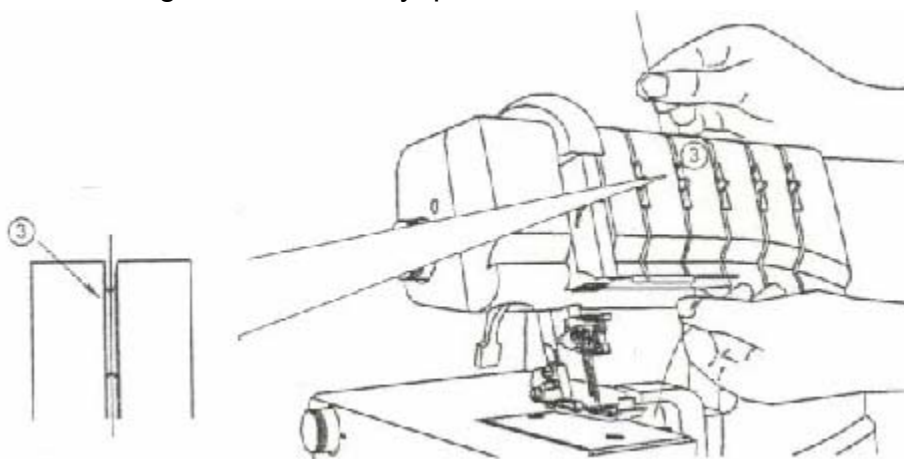

5. Continue to thread points 4-8. Slip the thread into the middle slot of the thread guide ⑤. Go over the take up lever ⑥. Continue by slipping the thread into the middle slot of the thread guides ⑦ and ⑧.

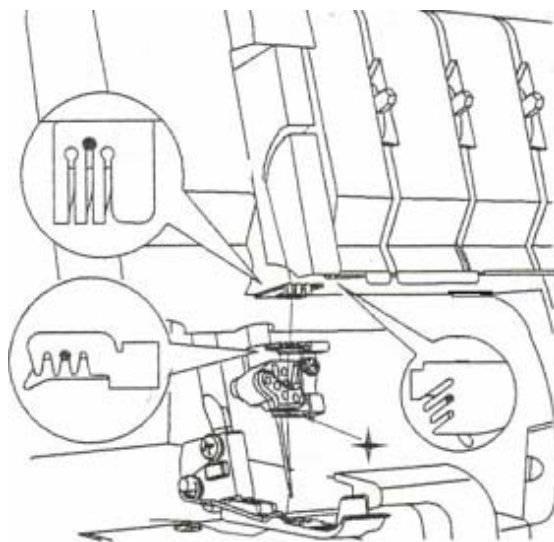

6. Before threading the eye of the needle, make sure the thread is in front of the thread guide located on the bottom of the needle clamp for the Cover Stitch or Chainstitch.

7. Thread the eye of the middle needle ⑨.

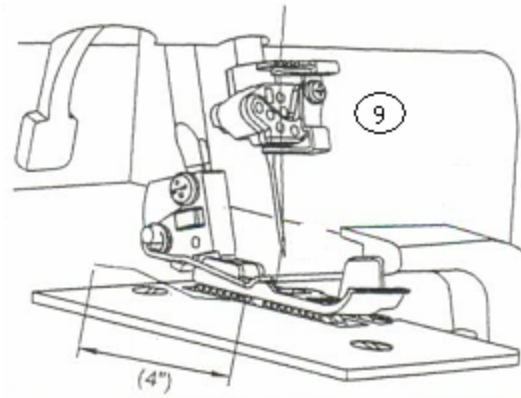
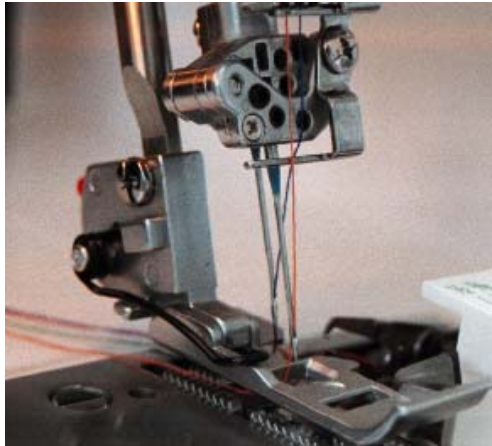

8. Draw about 4 inches of the thread through the needle eye towards the back of the machine.

9. Place the thread to the back, under the Presser Foot. Lower foot and sew.

# SINGER®

## Try It:

- ◆ Place two pieces of terrycloth right sides together.
- ◆ Align the fabric so that that the knife just slightly trims the fabric edge.
- ◆ Sew.

